

# Installation and Commissioning Guide

## iDirect Satellite Routers

**iDX Release 3.0**

**December 14, 2011**



---

---

Copyright © 2011 VT iDirect, Inc. All rights reserved. Reproduction in whole or in part without permission is prohibited. Information contained herein is subject to change without notice. The specifications and information regarding the products in this document are subject to change without notice. All statements, information, and recommendations in this document are believed to be accurate, but are presented without warranty of any kind, express, or implied. Users must take full responsibility for their application of any products. Trademarks, brand names and products mentioned in this document are the property of their respective owners. All such references are used strictly in an editorial fashion with no intent to convey any affiliation with the name or the product's rightful owner.

Document Name: PROC\_Remote Installation Guide iDX 3.0 Rev B\_12142011.pdf

Document Part Number: T0000380

---

---

# Revision History

The following table shows all revisions for this document. If you do not have the latest revision for your release, or you are not sure, please check the TAC webpage at: <http://tac.idirect.net>.

Revision	Date Released	Reason for Change(s)	Who Updated?
A	06/03/2011	First release of document for iDX 3.0	JVespoli
B	12/14/2011	Updated appendix on pointing using console port. The <code>options set</code> command is no longer supported.	JVespoli

---

---

# Contents

List of Figures . . . . .	vii
List of Tables . . . . .	viii
About This Guide . . . . .	ix
Purpose . . . . .	ix
Intended Audience . . . . .	ix
Contents Of This Guide . . . . .	ix
Document Conventions . . . . .	x
Related Documents . . . . .	x
Getting Help . . . . .	xi
<b>1 Getting Started</b>	<b>1</b>
1.1 Required Equipment . . . . .	1
1.2 When to Use This Guide . . . . .	1
1.3 How to Use This Guide . . . . .	2
<b>2 Installing Software on your Laptop</b>	<b>3</b>
2.1 Installing Software Downloaded from the Internet or CD . . . . .	3
2.2 Components of the iSite Software and Remote Modem Images . . . . .	4
<b>3 Connecting to the Satellite Router</b>	<b>5</b>
3.1 Access Your Satellite Router Using HyperTerminal . . . . .	5

---

3.2 Telnet to the iDirect Application . . . . .	8
3.3 Discovering the Satellite Router's IP Address and Application Version . . . . .	9
3.4 Modify Your Laptop's IP Address and Subnet Mask . . . . .	10
<b>4 Downloading Packages to the Satellite Router</b>	<b>13</b>
<b>5 Downloading the Options File to the Satellite Router</b>	<b>21</b>
<b>6 Configuring ACC Keys on a TRANSEC Remote</b>	<b>23</b>
<b>7 Setting Up your Antenna</b>	<b>25</b>
7.1 Select a Site for the Antenna . . . . .	25
7.2 Assemble the Antenna . . . . .	25
7.3 Align the Antenna toward the Spacecraft . . . . .	25
<b>8 Pointing the Antenna Using iSite</b>	<b>27</b>
8.1 Prepare the Indoor Unit (IDU) and Outdoor Unit (ODU) for Pointing . . . . .	27
8.2 Log in to Your Satellite Router . . . . .	27
8.3 Calculate Polarization, Azimuth, and Elevation . . . . .	28
8.4 Perform Pulse Width Modulation (PWM) Antenna Pointing . . . . .	30
<b>9 Tuning Antenna Pointing and Cross Polarization</b>	<b>35</b>
9.1 Set up the Satellite Router for Cross Polarization . . . . .	35
9.2 Set up iSite for Cross Polarization . . . . .	35
9.3 Preparing for the Cross Polarization Test . . . . .	36
9.4 Running the Cross Polarization Test . . . . .	36
9.4.1 Adjusting Azimuth . . . . .	36
9.4.2 Adjusting Elevation . . . . .	37
9.4.3 Adjusting the Polarization . . . . .	37
9.4.4 After the Cross Polarization Test . . . . .	37
<b>10 Establishing the 1 dB Compression Point</b>	<b>39</b>
<b>11 Recording Geo Location (Secure Mobile Remotes Only)</b>	<b>41</b>
11.1 Set the Satellite Router's Geo Location . . . . .	41

---



---

11.2 Verify the Satellite Router's Geo Location . . . . .	42
<b>12 Bringing the Satellite Router into the Network</b>	<b>43</b>
12.1 Evolution e8350 Satellite Router Front Panel LEDs . . . . .	43
12.2 iNFINITI Satellite Router Front Panel LEDs . . . . .	44
12.3 Evolution X3 and X5 Satellite Router Front Panel LEDs . . . . .	45
<b>13 Post Acquisition Activities</b>	<b>47</b>
13.1 Network Operator Duties . . . . .	47
13.2 Remote Installer Duties . . . . .	48
<b>14 Setting Initial Power and Maximum Power</b>	<b>49</b>
14.1 Determine the Remote's Initial Transmit Power . . . . .	49
14.2 Set the Initial Power and Maximum Power for a TDMA Remote . . . . .	51
14.3 Set the Initial Power and Maximum Power for an SCPC Remote . . . . .	52
<b>Appendix A Loading Images using the TFTP Server . . . . .</b>	<b>55</b>
<b>Appendix B Pointing the Antenna Using the Console Port . . . . .</b>	<b>57</b>
B.1 Performing Console Antenna Pointing . . . . .	57
B.2 Disable the Transmit PWM Voltage . . . . .	57
B.3 Starting Console Pointing . . . . .	58
B.4 Using the DVM for Console Pointing . . . . .	58
<b>Appendix C Disabling the PWM Voltage in iBuilder . . . . .</b>	<b>59</b>
<b>Appendix D Pinout for RJ-45 to DB-9 Adapter . . . . .</b>	<b>61</b>

---

---

## List of Figures

Figure 1. HyperTerminal Connection Description Dialog Box . . . . .	5
Figure 2. HyperTerminal Connect To Dialog Box . . . . .	6
Figure 3. HyperTerminal COM1 Properties Dialog Box . . . . .	6
Figure 4. Logging On to root Account During a Console Session . . . . .	7
Figure 5. Telnetting to iDirect Application During a Console Session . . . . .	8
Figure 6. Logging On to Admin Account During a Console Session . . . . .	8
Figure 7. Entering the <code>laninfo</code> Command . . . . .	9
Figure 8. Entering the <code>version</code> Command . . . . .	9
Figure 9. Local Area Connection Status Dialog Box . . . . .	10
Figure 10. Local Area Connection Properties Dialog Box . . . . .	10
Figure 11. Internet Protocol (TCP/IP) Dialog Box . . . . .	11
Figure 12. iSite Welcome Screen . . . . .	13
Figure 13. iSite Login Dialog Box . . . . .	14
Figure 14. Download Package Dialog Box . . . . .	15
Figure 15. Open Dialog Box with Images Folder . . . . .	16
Figure 16. Remote Packages for Satellite Router Models . . . . .	17
Figure 17. Download Package Dialog Box with Correct Selections . . . . .	18
Figure 18. Download Package Dialog Box: Information Section . . . . .	18
Figure 19. Remote Packages With X5 Remote Image File Selected . . . . .	19
Figure 20. Open Dialog Box with Remote Options File Selected . . . . .	21
Figure 21. iSite Options File Download Confirmation Dialog Box . . . . .	22
Figure 22. Resetting Satellite Router After Download . . . . .	22
Figure 23. ACC Key Example . . . . .	23
Figure 24. Antenna Elevation Offset . . . . .	26
Figure 25. iSite Login Dialog Box . . . . .	28
Figure 26. iSite Antenna Pointing Dialog Box . . . . .	29
Figure 27. Comparing Signal Strength . . . . .	31
Figure 28. Locking on to a Carrier Stream . . . . .	32
Figure 29. Cross Polarization Dialog Box . . . . .	35
Figure 30. Entering the <code>rmtstat</code> Command . . . . .	48
Figure 31. iMonitor Probe Dialog Box . . . . .	49
Figure 32. iMonitor Change Remote Tx Power Dialog Box . . . . .	50
Figure 33. iMonitor Remote Status Display . . . . .	50
Figure 34. iBuilder Remote Information Tab: Setting TDMA Initial and Max Power . . . . .	51
Figure 35. iBuilder Remote Information Tab: Transmit Properties . . . . .	52
Figure 36. SCPC Initial Power Dialog Box: Setting SCPC Initial and Max Power . . . . .	52
Figure 37. iBuilder Remote Information Tab: Disabling Tx PWM . . . . .	59

---

---

## List of Tables

Table 1. Remote Image Packages . . . . .	16
Table 2. Signal Strength Ranges (PWM) . . . . .	30
Table 3. iDirect Evolution e8350 LED Status . . . . .	43
Table 4. iDirect iNFINITI LED Status . . . . .	44
Table 5. iDirect Evolution X3 and X5 LED Status . . . . .	45
Table 6. Signal Strength Ranges (DVM). . . . .	58
Table 7. DB-9 to RJ-45 Adapter Pinout. . . . .	61

---

---

# About This Guide

## Purpose

This document provides detailed instructions for installing and commissioning iDirect Satellite Routers at remote sites.

## Intended Audience

This guide is written for iDirect installers and for other satellite technicians tasked with the installation and commissioning of iDirect iNFINITI or Evolution Satellite Routers.

## Contents Of This Guide

This document contains the following major sections:

- [“Getting Started”](#)
- [“Installing Software on your Laptop”](#)
- [“Connecting to the Satellite Router”](#)
- [“Downloading Packages to the Satellite Router”](#)
- [“Downloading the Options File to the Satellite Router”](#)
- [“Setting Up your Antenna”](#)
- [“Pointing the Antenna Using iSite”](#)
- [“Tuning Antenna Pointing and Cross Polarization”](#)
- [“Establishing the 1 dB Compression Point”](#)
- [“Recording Geo Location \(Secure Mobile Remotes Only\)”](#)
- [“Bringing the Satellite Router into the Network”](#)
- [“Post Acquisition Activities”](#)
- [“Setting Initial Power and Maximum Power”](#)
- [Appendix A, “Loading Images using the TFTP Server”](#)
- [Appendix B, “Pointing the Antenna Using the Console Port”](#)
- [Appendix C, “Disabling the PWM Voltage in iBuilder”](#)
- [Appendix D, “Pinout for RJ-45 to DB-9 Adapter”](#)

## Document Conventions

This section illustrates and describes the conventions used throughout the manual. Take a look now, before you begin using this manual, so that you'll know how to interpret the information presented.

Convention	Description	Example
<b>Blue Courier font</b>	Used when the user is required to enter a command at a command line prompt or in a console.	Enter the command: <code>cd /etc/snmp/</code>
Courier font	Used when showing resulting output from a command that was entered at a command line or on a console.	<code>crc report all</code> 3100.3235 : DATA CRC [ 1 ] 3100.3502 : DATA CRC [5818] 3100.4382 : DATA CRC [ 20]
<b>Bold Trebuchet font</b>	Used when referring to text that appears on the screen on a windows-type Graphical User Interface (GUI).  Used when specifying names of commands, menus, folders, tabs, dialogs, list boxes, and options.	1. If you are adding a remote to an inroute group, right-click the Inroute Group and select <b>Add Remote</b> .  The <b>Remote</b> dialog box has a number of user-selectable tabs across the top. The <b>Information</b> tab is visible when the dialog box opens.
<b>Blue Trebuchet font</b>	Used to show all hyperlinked text within a document.	For instructions on adding a line card to the network tree and selecting a Hub RFT for the line card, see <a href="#">“Adding a Line Card” on page 108</a> .
<b>Bold italic Trebuchet font</b>	Used to emphasize information for the user, such as in notes.	<b>Note:</b> <i>Several remote model types can be configured to use link encryption.</i>
<b>Red italic Trebuchet font</b>	Used when the user needs to <i>strictly</i> follow the instructions or have additional knowledge about a procedure or action.	<b>WARNING!</b> <i>The following procedure may cause a network outage.</i>

## Related Documents

The following iDirect documents are available at <http://tac.idirect.net> and may also contain information relevant to this release. Please consult these documents for information about installing and using iDirect's satellite network software and equipment.

- *iDX Release Notes*
- *iDX Software Installation Guide or Network Upgrade Procedure Guide*
- *iDX iBuilder User Guide*

- *iDX iMonitor User Guide*
- *iDX Technical Reference Guide*
- *iDX Software Installation Checklist/Software Upgrade Survey*
- *iDirect Hub Readiness Checklist*
- *iDX Link Budget Analysis Guide*

## Getting Help

The iDirect Technical Assistance Center (TAC) is available to help you 24 hours a day, 365 days a year. Software user guides, installation procedures, a FAQ page, and other documentation that supports our products are available on the TAC webpage. Please access our TAC webpage at: <http://tac.idirect.net>.

If you are unable to find the answers or information that you need, you can contact the TAC at (703) 648-8151.

If you are interested in purchasing iDirect products, please contact iDirect Corporate Sales by telephone or email.

Telephone: (703) 648-8000

Email: SALES@iDirect.net

iDirect strives to produce documentation that is technically accurate, easy to use, and helpful to our customers. Your feedback is welcomed! Send your comments to [techpubs@idirect.net](mailto:techpubs@idirect.net).



---

---

# 1 Getting Started

This Installation and Commissioning Guide is intended to help you quickly install and commission iDirect Satellite Routers at remote sites. This document applies to both iNFINITI and Evolution series Satellite Routers.

iDirect Satellite Routers run the Linux operating system.

## 1.1 Required Equipment

You will need the following equipment and software to successfully commission the Satellite Router in the field:

- A console cable with DB9 adapter
- A crossover LAN cable
- A digital (or analog) voltmeter plus adaptor from voltmeter to IFL “F” connector
- A hand-held GPS unit or a map that shows your current geographic location coordinates
- A laptop (or PC) with:
  - Window 7, Windows XP or Windows 2000, Service Pack 3
  - A minimum of 512 MB RAM
  - A minimum processor speed of 1 GHz
  - A minimum of 50 MB of free disk space
- The correct options file provided to you by your Service Provider
- The correct remote application, firmware and board support packages provided to you by your Service Provider

**Note:** *iDirect recommends disabling the firewall on your laptop to ensure complete functionality.*

## 1.2 When to Use This Guide

Use this guide when first installing and commissioning an iDirect Satellite Router. Also, you must repeat the procedures in this manual if you move your iDirect Satellite Router from one established location to another.

Once you have successfully commissioned an iDirect Satellite Router at a specific location, it can be reset at any time. Resetting the router causes it to perform a self-test startup sequence and re-acquire the satellite network.

## 1.3 How to Use This Guide

This guide documents the step-by-step procedures required to commission and install your Satellite Router. The procedures appear in the order in which they should be performed. Therefore, be sure to perform the steps in this guide in the sequence in which they are presented.

---

---

# 2 Installing Software on your Laptop

These instructions guide you through the process of installing the iSite software and remote images onto your laptop or PC. The software may be downloaded from the TAC Web Page (<http://tac.idirect.net>) or it may be distributed to you on a CD.

## 2.1 Installing Software Downloaded from the Internet or CD

iSite software is distributed in a ZIP file that also includes the remote modem software. After receiving the compressed file, *remote-version.zip*, follow these steps to install the files on your laptop:

1. Copy the ZIP file to a directory where you can extract the compressed files. Be sure to store the files in a directory on your laptop that you can locate later.
2. Extract the files using a utility that understands the .zip format or right-click the ZIP file and select Extract All.
3. If desired, create a shortcut to iSite.exe on your desktop or Windows taskbar. iSite is located in the iSite folder.

The following folders containing iSite and the remote image files are created on your laptop when you extract the compressed files from the ZIP file:

```
Remote Software and iSite - version
  iSite/
  Images/
    Remote_Evolution_e8series
    Remote_Evolution_X3_X5
    Remote_iNFINITI
    Remote_eP100
```

where: *version* is the iDX software version number.

## 2.2 Components of the iSite Software and Remote Modem Images

The iSite Software and the image files for the iDirect Satellite Routers are bundled together in the download. This includes:

- The NMS iSite program and support files (in the iSite folder.)
- The Evolution e8000 Series Satellite Router application and image files (in the Remote\_Evolution\_e8series folder.)
- The Evolution X3 and X5 Satellite Router application and image files (in the Remote\_Evolution\_X3\_X5 folder.)
- The iNFINITI Satellite Router application and image files (in the Remote\_iNFINITI folder.)
- The Evolution eP100 Satellite Router application and image files (in the Remote\_eP100 folder.)

---

---

# 3 Connecting to the Satellite Router

You can use any terminal emulator to connect to the Satellite Router console. The HyperTerminal application comes pre-installed on most Windows machines. This section uses HyperTerminal to illustrate how to connect to your Satellite Router.

## 3.1 Access Your Satellite Router Using HyperTerminal

1. Connect the RJ-45 to DB-9 adapter to the COM1 port of your laptop.
2. Plug the other end of the cable into the Console port of the iDirect Satellite Router.
3. Power on your Satellite Router.
4. In the Windows Start menu of your Laptop, select **All Programs**→**Accessories**→**Communications**→**HyperTerminal** to open the Connection Description dialog box.

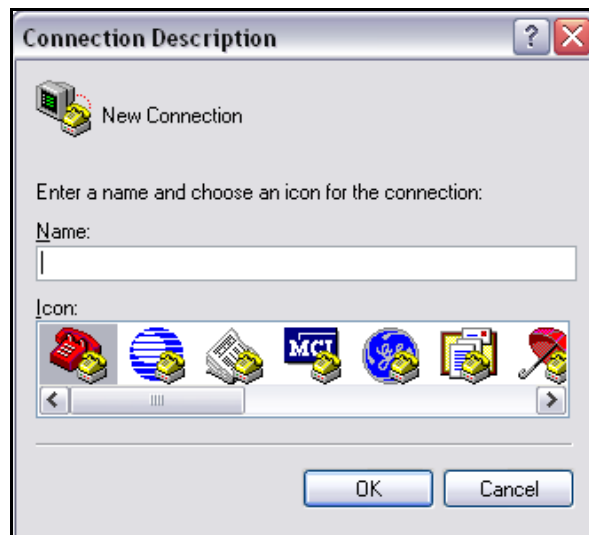

Figure 1. HyperTerminal Connection Description Dialog Box

5. In the Connection Description dialog box, type a Name for the connection, such as Satellite Router Console.
6. Optionally, you can select an Icon other than the default icon for your connection.

7. Click OK to display the Connect To dialog box.



Figure 2. HyperTerminal Connect To Dialog Box

8. Select COM1 from the Connect using drop-down menu.
9. Click OK in the Connect To dialog box to view the COM1 Properties dialog box.

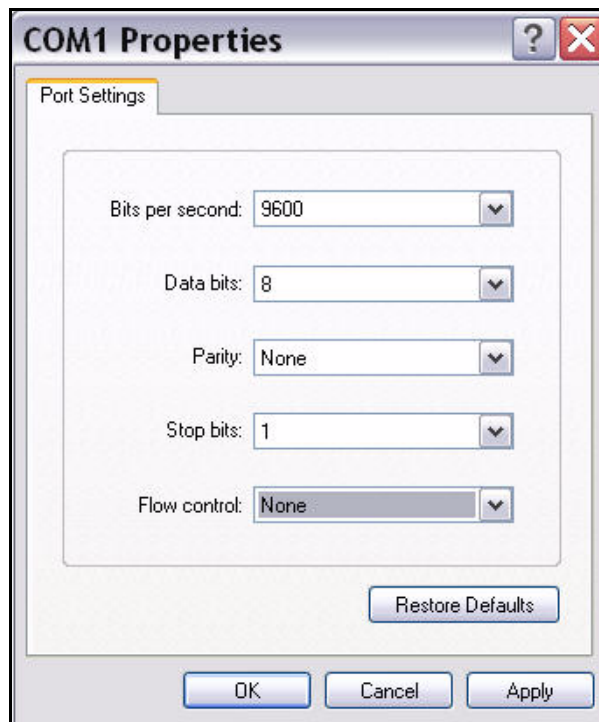

Figure 3. HyperTerminal COM1 Properties Dialog Box

10. Use the drop-down menus to select the COM1 Properties. Select the same settings as those shown in [Figure 3](#).
  - Bits per second: 9600
  - Data bits: 8
  - Parity: None
  - Stop bits: 1
  - Flow control: None
11. Click OK to connect to the Satellite Router.

**Note:** *If this is a mobile remote and you lose contact with it, the console port settings will change during the boot process to 4800 bps. All other settings will remain the same. To re-establish communication with the console port, you must change your serial port settings to match the new settings.*

12. Press Enter a few times to generate a response from the Satellite Router. If you are successful, the console prompt will display. If you are unable to generate a response from the Satellite Router, re-examine your settings to be certain that they are correct.
13. At the iDirect login prompt, enter **root** ([Figure 4](#)).

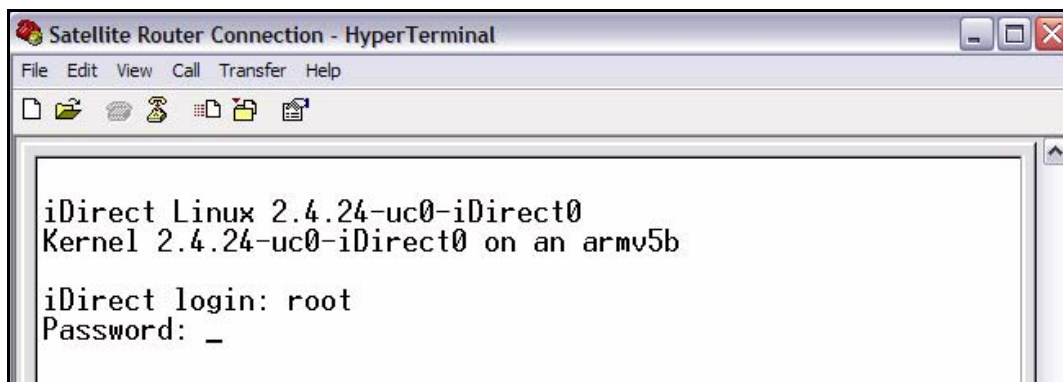

Figure 4. Logging On to root Account During a Console Session

14. At the Password prompt, enter the default password, **iDirect**.

You are now logged on to the Linux software running on your Satellite Router. Perform the steps in the next section to telnet to the iDirect Application.

## 3.2 Telnet to the iDirect Application

1. At the Linux prompt (#), enter `telnet localhost` to telnet to the iDirect application (Figure 5).

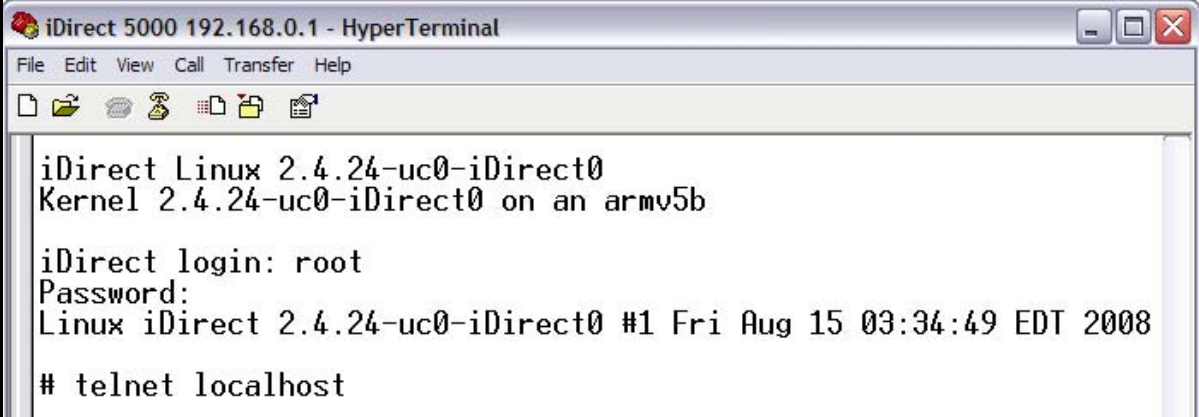

```
iDirect 5000 192.168.0.1 - HyperTerminal
File Edit View Call Transfer Help
iDirect Linux 2.4.24-uc0-iDirect0
Kernel 2.4.24-uc0-iDirect0 on an armv5b
iDirect login: root
Password:
Linux iDirect 2.4.24-uc0-iDirect0 #1 Fri Aug 15 03:34:49 EDT 2008
# telnet localhost
```

Figure 5. Telnetting to iDirect Application During a Console Session

2. At the Username prompt, enter the default user name, `admin` (Figure 6).

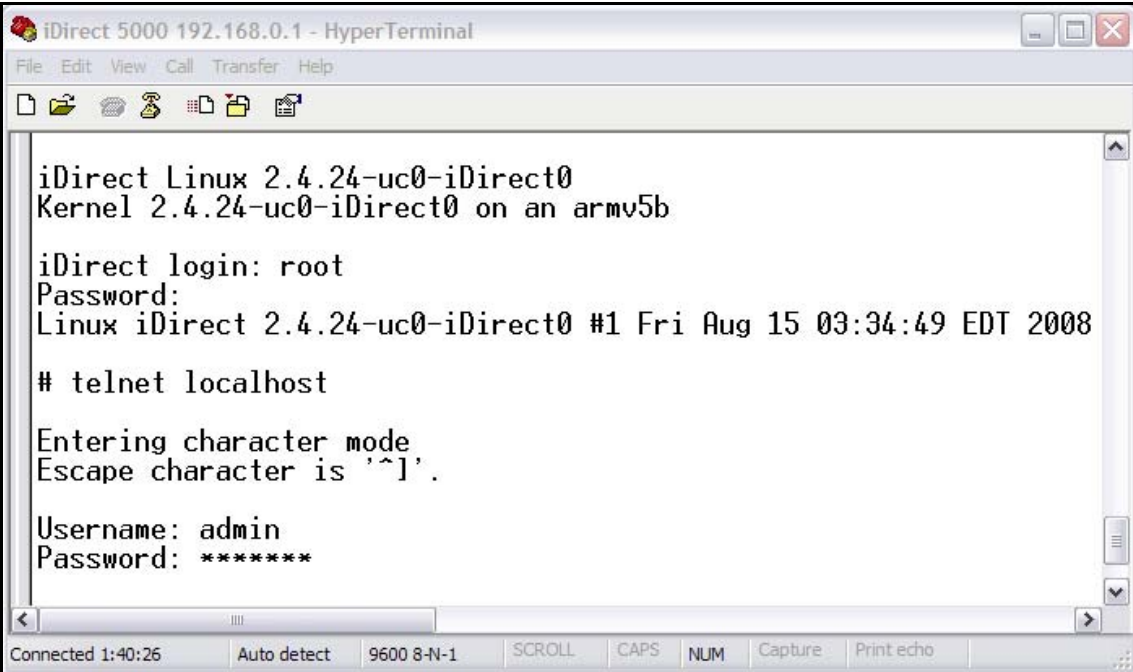

```
iDirect 5000 192.168.0.1 - HyperTerminal
File Edit View Call Transfer Help
iDirect Linux 2.4.24-uc0-iDirect0
Kernel 2.4.24-uc0-iDirect0 on an armv5b
iDirect login: root
Password:
Linux iDirect 2.4.24-uc0-iDirect0 #1 Fri Aug 15 03:34:49 EDT 2008
# telnet localhost
Entering character mode
Escape character is '^I'.
Username: admin
Password: *****
Connected 1:40:26 Auto detect 9600 8-N-1 SCROLL CAPS NUM Capture Print echo
```

Figure 6. Logging On to Admin Account During a Console Session

3. At the Password prompt, enter the default password, `iDirect`. (In some cases, `P@55w0rd!` may be the default password.)

You are now logged on to the iDirect application. To determine the IP address and firmware version of the Satellite router, perform the steps in the next section.

### 3.3 Discovering the Satellite Router's IP Address and Application Version

1. At the Satellite Router prompt, enter the command `laninfo` (Figure 7).

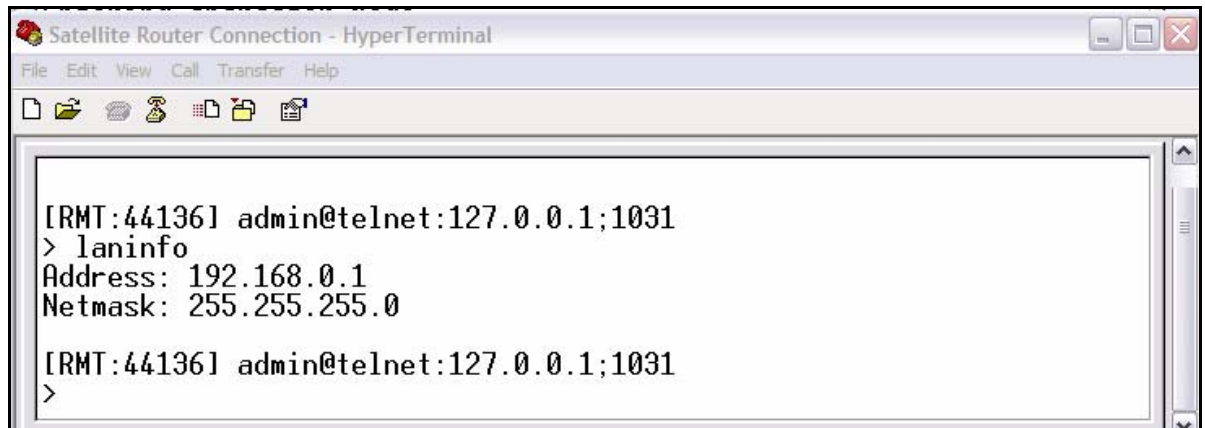

```
Satellite Router Connection - HyperTerminal
File Edit View Call Transfer Help

[IRMT:44136] admin@telnet:127.0.0.1;1031
> laninfo
Address: 192.168.0.1
Netmask: 255.255.255.0

[IRMT:44136] admin@telnet:127.0.0.1;1031
>
```

Figure 7. Entering the `laninfo` Command

When you enter the `laninfo` command, the IP Address and Netmask currently assigned to the Satellite Router are displayed. In the example in Figure 7, the IP address is 192.168.0.1 and the subnet mask is 255.255.255.0. You will need this information to configure your laptop to be in the same subnet as the Satellite Router.

Now that you have determined the IP address of the Satellite Router, determine the current version of the iDirect application to know whether or not you should select Secure Connection when first logging on to iSite. See page 14 for details.

2. At the Satellite Router prompt, enter the `version` command to determine the current version of the iDirect application running on the Satellite Router (Figure 8).

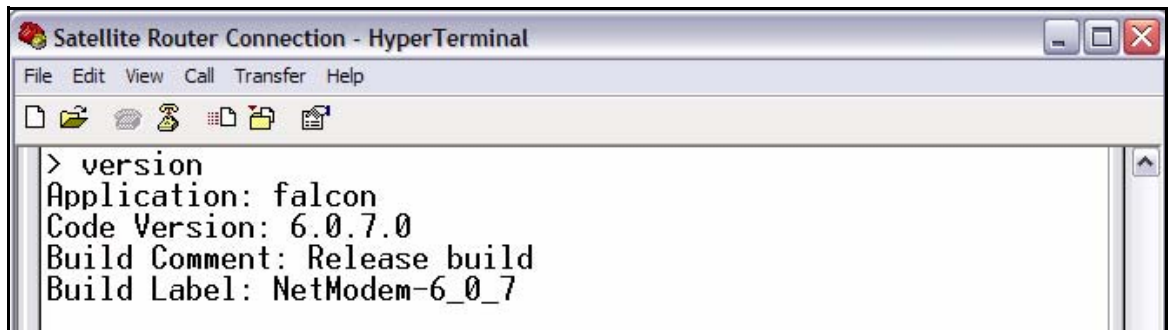

```
Satellite Router Connection - HyperTerminal
File Edit View Call Transfer Help

> version
Application: falcon
Code Version: 6.0.7.0
Build Comment: Release build
Build Label: NetModem-6_0_7
```

Figure 8. Entering the `version` Command

In Figure 8, the Satellite Router is running Code Version 6.0.7.0.

## 3.4 Modify Your Laptop's IP Address and Subnet Mask

To modify the IP address of your laptop, you must bring up the Windows Network Connections window and modify the TCP properties.

1. From your computer's Control Panel, double-click Network Connections.
2. Double-click the icon for your Local Area Connection to launch the Local Area Connection Status dialog box.

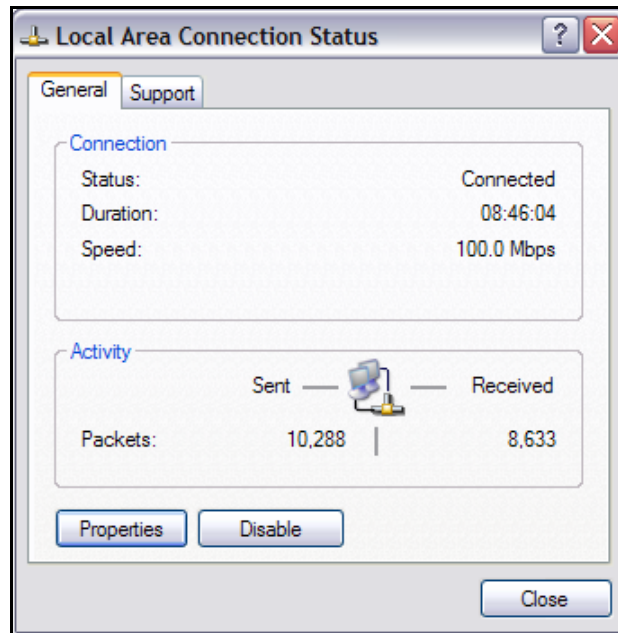

Figure 9. Local Area Connection Status Dialog Box

3. Click the Properties button to display the Local Area Connection Properties dialog box.

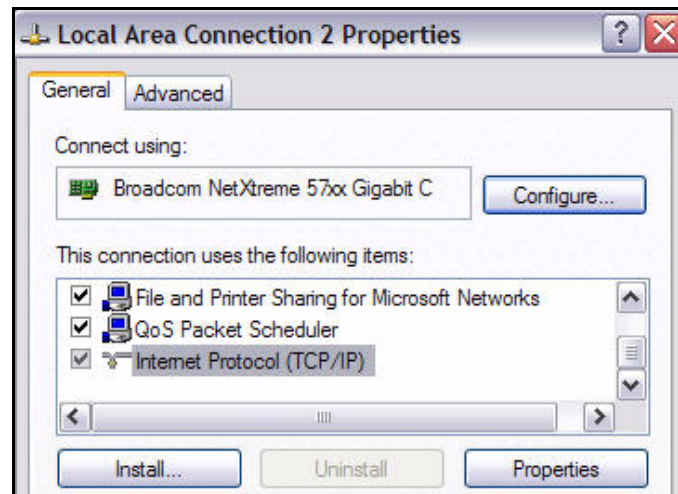

Figure 10. Local Area Connection Properties Dialog Box

4. In the Local Area Connection Properties dialog box, under This connection uses the following items: select Internet Protocol (TCP/IP) as shown in [Figure 10](#).
5. Click the Properties button to display the Internet Protocol (TCP/IP) Properties dialog box.

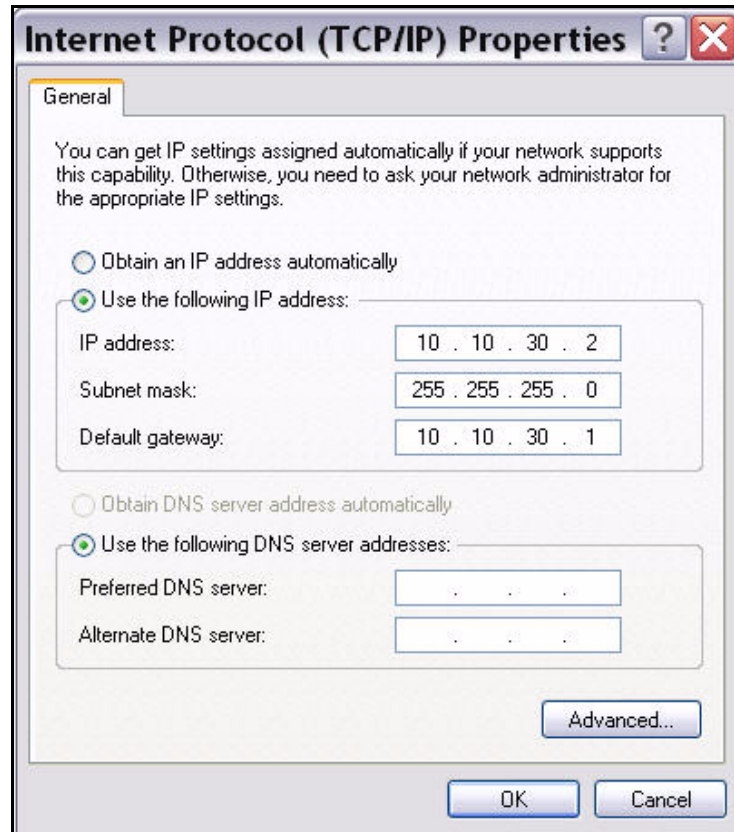

Figure 11. Internet Protocol (TCP/IP) Dialog Box

6. In the Internet Protocol (TCP/IP) Properties dialog box, select Use the following IP address. Type an IP address that is inside the range specified by the Satellite Router's IP address and subnet mask.
7. Type the same Subnet mask that you retrieved from the Satellite Router using the `Ianinfo` command. For the purposes of a local connection, you do not need to specify DNS server addresses.
8. Type the Satellite Router's IP address as the Default Gateway address.
9. Click OK to save your changes.

You are now ready to connect to the Satellite Router using iSite.

**Note:** *You can ping the IP address of the Satellite Router to verify that the connection has been successfully established.*



---

# 4 Downloading Packages to the Satellite Router

Perform the steps in this section to download the image packages containing software and firmware for the current release from your laptop to the Satellite Router.

1. Connect the LAN port of the laptop to the LAN B port of the Satellite Router using a crossover LAN cable. (Newer laptops adjust when you use a straight through cable, but older machines do not.)
2. Launch iSite. iSite automatically discovers the Satellite Router in the iSite Tree View, as shown in [Figure 12](#).

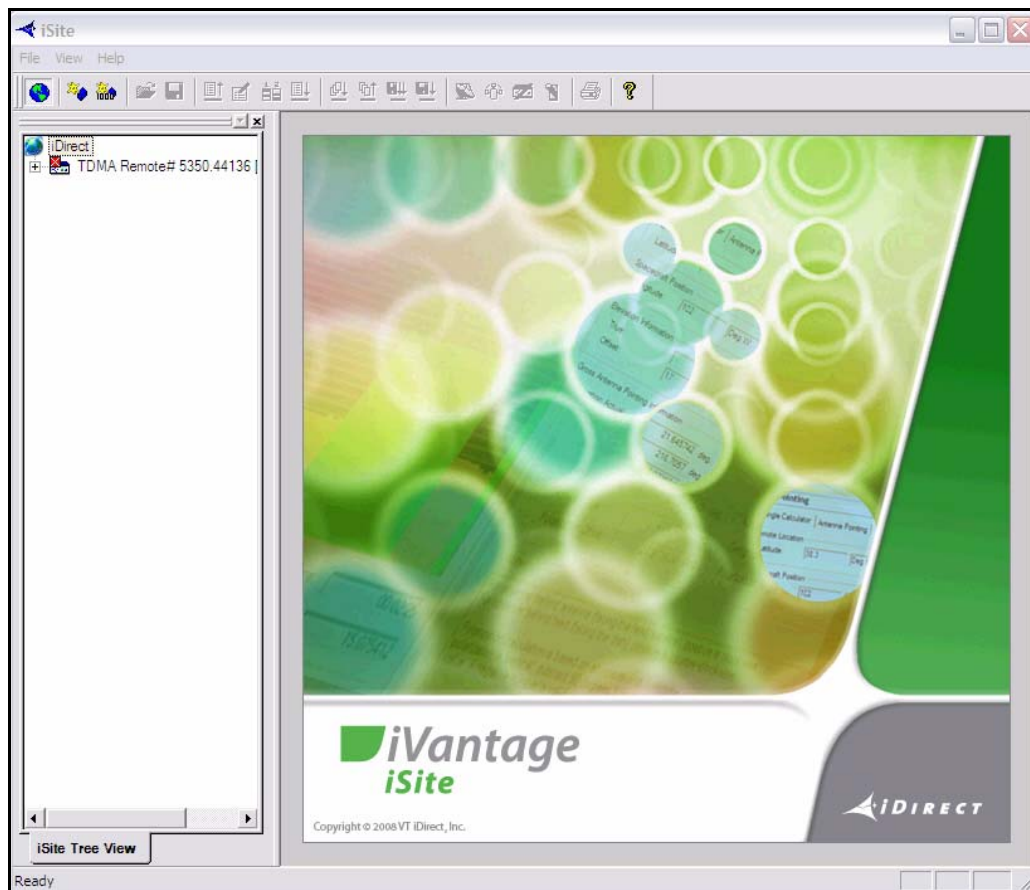
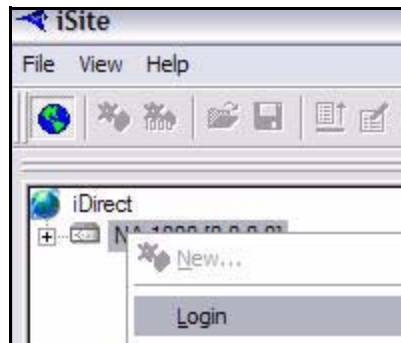

Figure 12. iSite Welcome Screen

**Note:** If iSite does not automatically discover the Satellite Router, right-click the iDirect globe in the iSite tree and select **New** from the menu to add an unknown element to the tree. Then right-click the new element and log on using the IP address of the router.

3. Right-click the Satellite Router in the iSite Tree View and select Login.



The Login dialog box opens, pre-configured with your Satellite Router's IP Address.



Figure 13. iSite Login Dialog Box

4. Type the default Password, **iDirect**. (In some cases, **P@55w0rd!** may be the default password.)
5. In the Login as section of the dialog box:
  - a. Select **Admin**.
  - b. Select or clear the Secure Connection check box, depending on the version of the iDirect application that you determined when you entered the **version** command on [page 9](#).  
If a pre-7.1 version of the iDirect application is currently installed on the Satellite Router, clear the Secure Connection check box. If later images have already been installed, select Secure Connection.
6. Click OK to log on to the Satellite Router.

- Right-click the Satellite Router in the iSite Tree View and select Download Package.

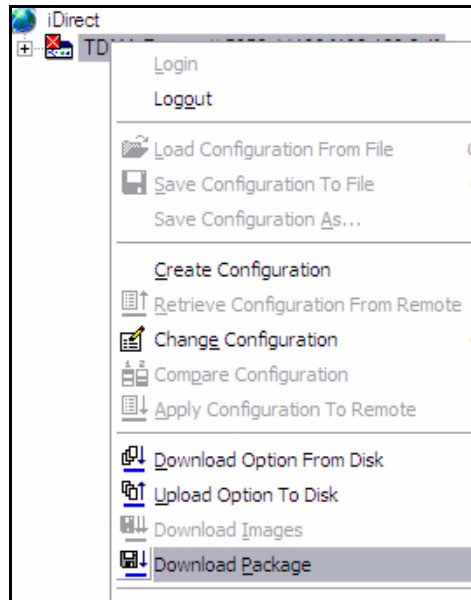

The Download Package dialog box opens.

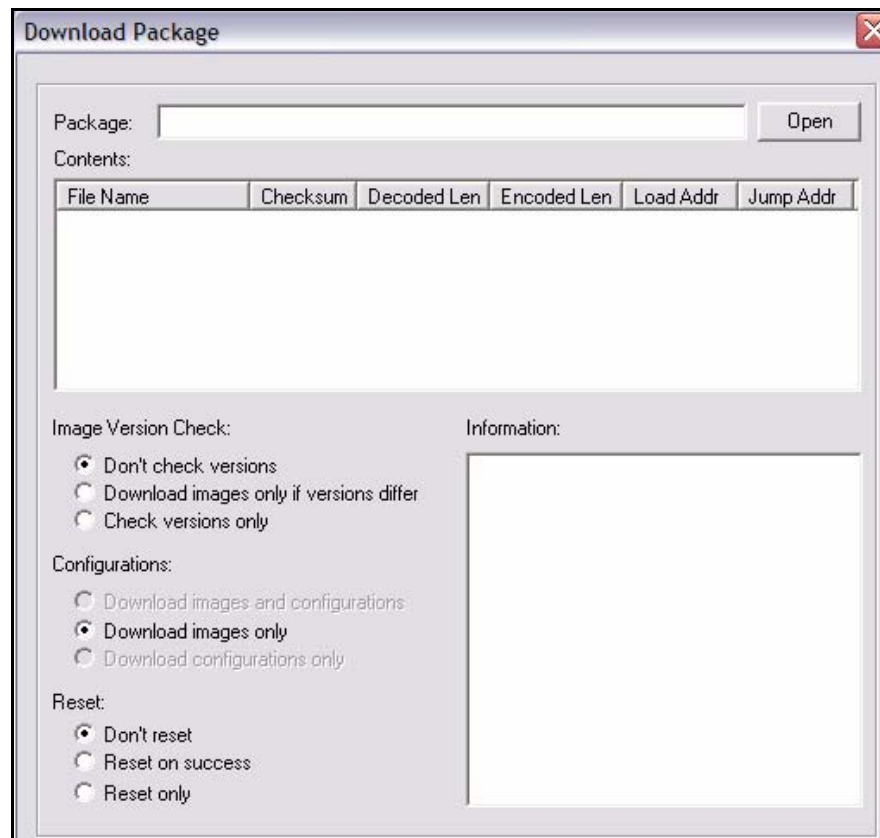

Figure 14. Download Package Dialog Box

8. In the Download Package dialog box, click the Open button to display the Open dialog box.

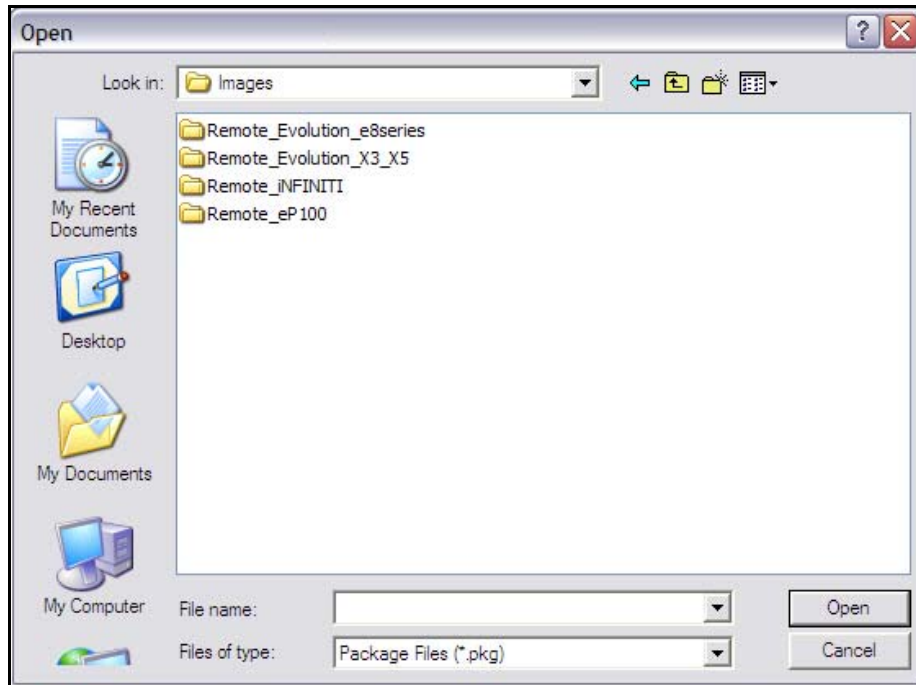

Figure 15. Open Dialog Box with Images Folder

9. Navigate to the remote packages on your laptop. They are located in the Images folder for your release, as illustrated in [Figure 15](#).
10. In the Open dialog box, double-click the folder for your Satellite Router model to open the folder. For each supported model type, [Table 1](#) identifies the folder containing the packages you must download and the required packages.

Table 1. Remote Image Packages

Satellite Modem	Location	Packages to Download
Evolution e8000 Series	/Images/Remote_Evolution_e8series	linux_2.6_bsp package e8_rmt package
Evolution X3 Remote	/Images/Remote_Evolution_X3_X5	linux_2.4_bsp package evo_x3_rmt package
Evolution X5 Remote	/Images/Remote_Evolution_X3_X5	linux_2.4_bsp package evo_x5_rmt package
iNFINITI Series (Except 31xx Remotes)	/Images/Remote_iNFINITI	linux_2.4_bsp package remote package
iNFINITI 31xx Remotes	/Images/Remote_iNFINITI	linux_2.4_bsp package remote_3xxx package
Evolution eP100 Remote	/Images/Remote_eP100	linux_2.6_bsp package ep100_rmt package

**Note:** Beginning with iDX Release 2.0, Evolution Remote Satellite routers that can receive either a DVB-S2 or an iNFINITI outbound carrier no longer require a different remote software package for each carrier type. You should download the remote package specified in [Table 1](#) regardless of the outbound carrier type.

11. You must download two packages to your Satellite Router: the Linux Board Support Package (BSP) and the correct remote image package. [Figure 16](#) shows the packages for each Satellite Router model supported in iDX Release 3.0.

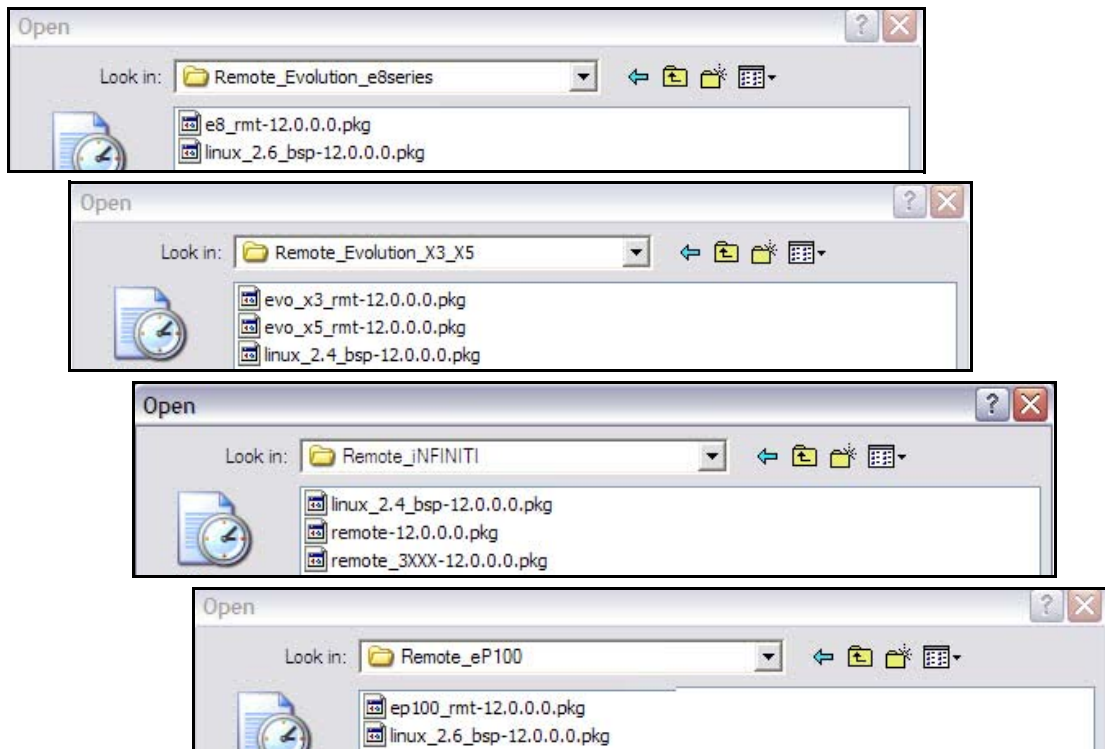

Figure 16. Remote Packages for Satellite Router Models

**Note:** You must download both packages for your model type to your Satellite Router, beginning with the Linux BSP package. (See [Table 1](#).)

**Note:** During this time, observe the output of both iSite and a console session to verify that the download is complete before going on to the next step. iSite may not be synchronized with the console.

12. Double-click the Linux Board Support Package (BSP) in the Open dialog box to return to the Download Package dialog box.

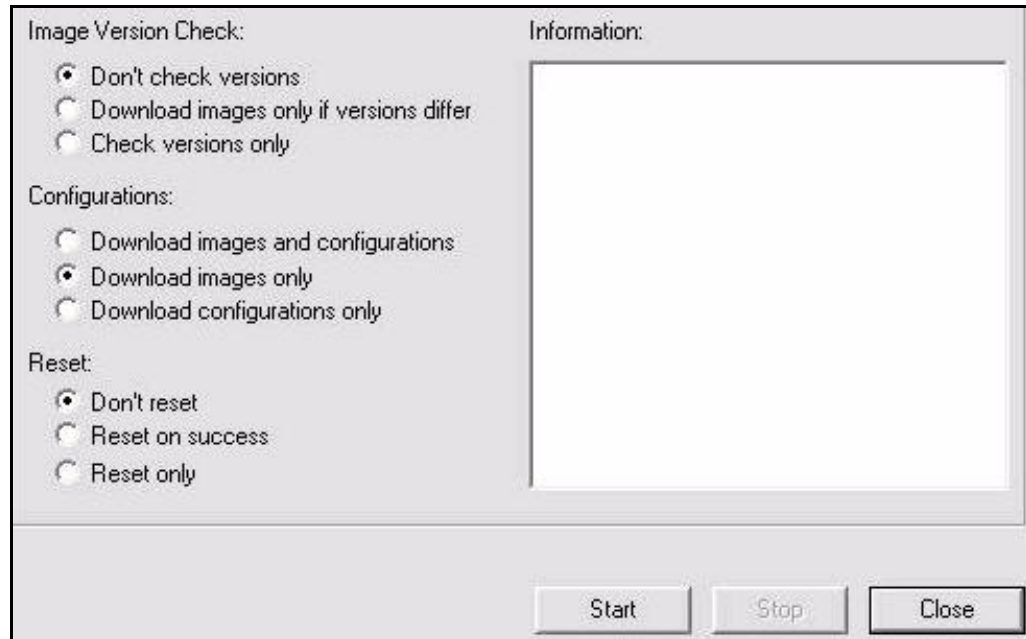

Figure 17. Download Package Dialog Box with Correct Selections

13. In the Download Package dialog box, select the following options as shown in [Figure 17](#).
  - Don't check versions
  - Download images only
  - Don't reset
14. Click the Start button.
15. Wait while the download progresses. Observe the Information section of the Download Package dialog box until the word Done is displayed.

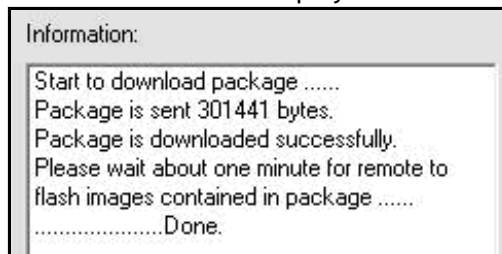

Figure 18. Download Package Dialog Box: Information Section

When the download of the board support package has finished, perform the remaining steps in this section to download the remote image package to the Satellite Router.

16. Click the Open button in the Download Package dialog box again (Figure 14 on page 15) and navigate back to the remote packages on your laptop.

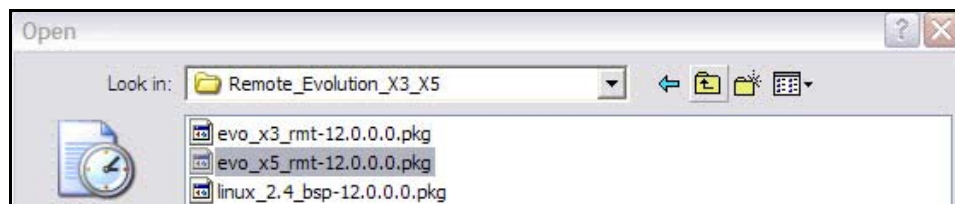

Figure 19. Remote Packages With X5 Remote Image File Selected

17. Double-click the remote image package in the Open dialog box to return to the Download Package dialog box.

**Note:** *If you are downloading an Evolution X3 or X5 remote, be sure to select the correct remote package.*

**Note:** *If you are downloading an iNFINITI 3100 series remote, be sure to select the remote\_3XXX package.*

The example in Figure 19 shows the Open dialog box with the remote image file for Evolution X5 Remote Satellite Routers selected. If you were downloading an Evolution X3 remote, you would select the X3 remote package instead.

18. In the Download Package dialog box, select the following options as shown in Figure 17 on page 18.
- Don't check versions
  - Download images only
  - Don't reset
19. Click the Start button.
20. Wait while the download progresses. Observe the Information section of the Download Package dialog box until the word Done is displayed.

Once you have downloaded both packages to your Satellite Router, perform the steps in the next section to download the options file.



---

---

# 5 Downloading the Options File to the Satellite Router

Perform the steps in this section to download the remote options file to the Satellite Router.

**Note:** *If this remote is being commissioned in a TRANSEC network and does not yet have its X.509 certificate, ensure that `auth_level_required = 0` in the options file before you download the options file to the remote.*

1. In iSite, right-click the Satellite Router and select Download Option from Disk.

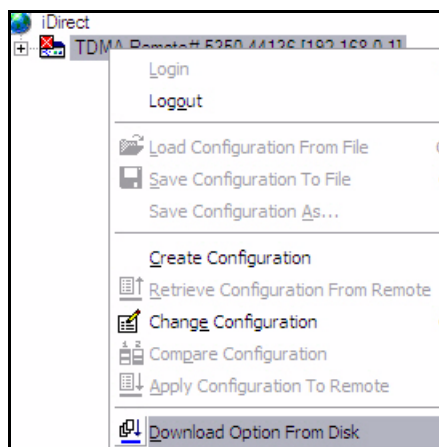

2. In the Open dialog box, navigate to the folder on your laptop containing the remote options file.

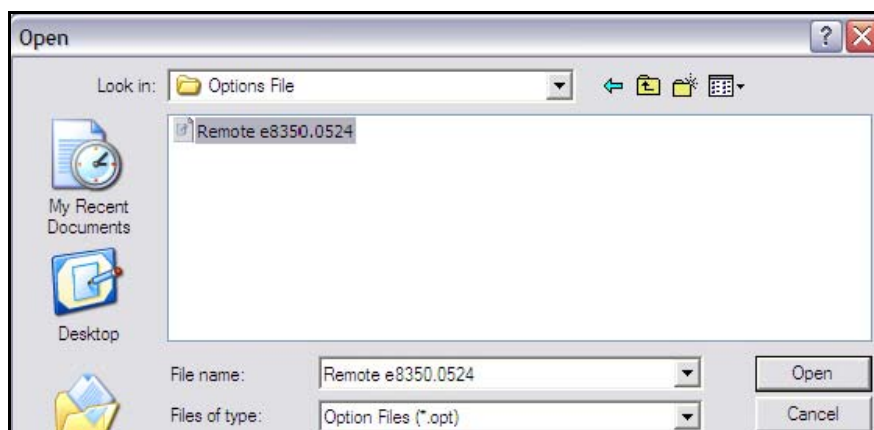

Figure 20. Open Dialog Box with Remote Options File Selected

3. Select the options file and click the Open button.
4. When iSite requests confirmation of the download request, click the Yes button.

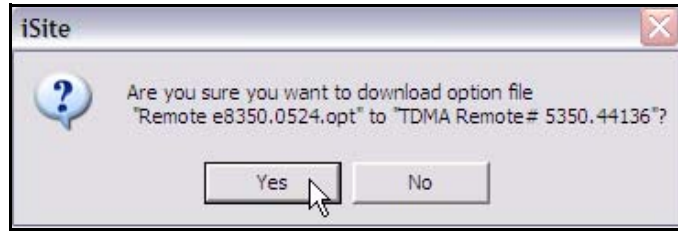

Figure 21. iSite Options File Download Confirmation Dialog Box

5. When iSite reports a successful download, click the Reset Now button to reset the Satellite Router.

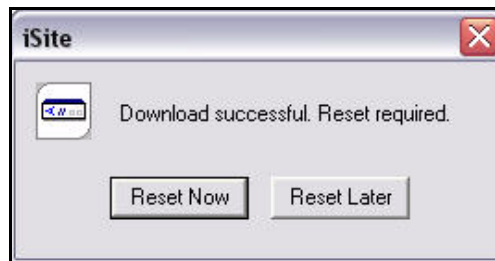

Figure 22. Resetting Satellite Router After Download

**Note:** *Resetting logs you out of the Satellite Router. After the reset, the IP address of the Satellite Router changes to the value provided by your Service Provider in the downloaded options file.*

**Note:** *If your Service Provider changed your Satellite Router password from the default iDirect password, log on to the router using the new password.*

---

---

# 6 Configuring ACC Keys on a TRANSEC Remote

Only perform the procedures in this section if you are commissioning a remote in a TRANSEC network.

Before a newly-commissioned remote can acquire an existing TRANSEC network, the following two conditions must be met:

- If an X.509 certificate has not yet been issued for this remote, then authentication must be disabled for the remote at the hub and in the remote options file.
- The current Network Acquisition Keys (ACC Keys) must be present on the remote modem.

If the remote is not yet certified for the TRANSEC network, then the options file that you downloaded in the previous section should already have authentication disabled.

Follow these steps only if the remote does not yet have its X.509 certificate:

1. Verify that the following parameter is set to 0 in the remote options file:  
`auth_level_required = 0`
2. If `auth_level_required = 1`, edit the options file to change it to 0 and download the modified options file to the remote modem again.
3. Coordinate with the Network Operator to select Disable Authentication on the iBuilder Remote Information tab and apply the hub-side changes.

At this point, authentication is disabled at the hub and on the remote.

To load the ACC keys onto the remote:

1. If you do not already have the current ACC Keys and the passphrase, coordinate with the Network Operator to obtain them over a secure link.

Sample ACC Keys are shown in [Figure 23](#).

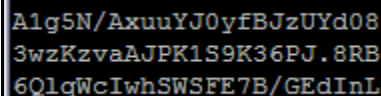

```
A1g5N/AxuuYJ0yfBJzUYd08
3wzKzvaAJPK1S9K36PJ.8RB
6Q1qWcIwhSWSFE7B/GEdInL
```

Figure 23. ACC Key Example

**Note:** *The procedure for retrieving the current ACC Keys from the hub is documented in the appendix “Managing TRANSEC Keys” of the iBuilder User Guide.*

2. Open a terminal session to the Satellite Router and log on to the root account. (See [“Access Your Satellite Router Using HyperTerminal” on page 5](#) for details.)
3. Enter the command:  
`telnet localhost`
4. At the Username prompt, log on to the admin account.
5. At the command line prompt, enter the command:  
`csp enable`
6. Enter the command:  
`keyroll_mgr setACCKey`
7. At this point, you will be prompted for each of the three segments (lines) of the encrypted key and the passphrase. Respond to each prompt with the requested information. You can type `Q` to quit at any time.
8. When asked if you want to continue, enter:  
`Yes`

You should see a message stating that the Network Acquisition Key has been updated.

---

---

# 7 Setting Up your Antenna

Perform the steps in this section to set up your antenna.

## 7.1 Select a Site for the Antenna

1. Select a level surface that is approximately 10 feet by 10 feet.
2. Verify that nothing is blocking the line of site to the satellite in azimuth and elevation.
3. Verify that the IFL cable can reach the Satellite Router from the antenna location. (RG-6 IFL cable may be used up to a distance of 250 feet. If your run is longer, RG-11 cable must be used up to a distance of 500 feet.)
4. Ensure that the IFL cable does not cross roads or heavy foot-traffic areas.

## 7.2 Assemble the Antenna

Assemble the antenna using the supplied assembly instructions. After installation, ensure that the following are true:

1. The antenna base is on a stable surface that will not shift during windstorms.
2. Ballast is installed on the antenna base.
3. The mast pipe is plumb.

## 7.3 Align the Antenna toward the Spacecraft

You are now ready to perform the initial alignment of your antenna.

1. Set the antenna's polarization to the approximate value provided by iSite's Look Angle Calculator.
2. Set the elevation to the value provided by iSite's Look Angle Calculator.

**Note:** *Using the Look Angle Calculator is discussed in detail in [“Calculate Polarization, Azimuth, and Elevation” on page 28.](#)*

**Note:** To take into consideration the magnetic angle of declination in your location and to ensure that the compass reading is correct, you must:

1. Take a reading at the back of the antenna

2. Mark a reference point some distance ahead of the antenna, so that you have something to point to.

**Keep in mind that large metal objects can cause inaccurate compass readings.**

A 1.8 meter antenna has 22.6° offset and a 1.2 meter antenna has 17° offset. For example, an elevation angle of 50° is set as follows for a 1.8 meter antenna:

$$50^{\circ} - 22.6^{\circ} = 27.4^{\circ}$$

The backplane is perpendicular to the line of sight of the antenna plus 22.6°. If the backplane is 90°, the antenna elevation angle is 22.6°.

In the example above the antenna is elevated from 90° to 117.4° or, depending on the type of inclinometer being used, a reading of 62.6°, to reach an elevation angle to 50°.

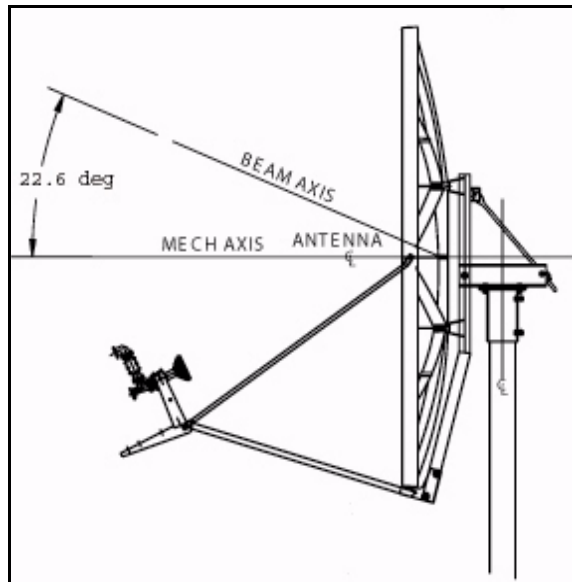

Figure 24. Antenna Elevation Offset

To prepare the antenna for pointing, move the antenna away from the desired azimuth, by swinging the antenna 20° in azimuth. This will enable you to get a clear sky reading and compare signal strengths during the antenna pointing procedure.

---

---

# 8 Pointing the Antenna Using iSite

This section explains how to point the antenna using Pulse Width Modulation and iSite. An alternative pointing method is described in [Appendix B, “Pointing the Antenna Using the Console Port”](#) on page 57.

## 8.1 Prepare the Indoor Unit (IDU) and Outdoor Unit (ODU) for Pointing

1. If your Satellite Router is powered on, power it off at this time.
2. Ensure that the Receive IFL cable is connected from the LNB to the Satellite Router.
3. Ensure that the Transmit IFL cable is connected to the Satellite Router.
4. Disconnect the Transmit IFL cable from the BUC and connect it to a Digital Volt Meter.
5. Power on your Satellite Router.

## 8.2 Log in to Your Satellite Router

After powering on your Satellite Router, you should still have IP connectivity. Therefore, you can continue to access your Satellite Router using iSite.

1. Right-click your Satellite Router in the iSite Tree and select Login.

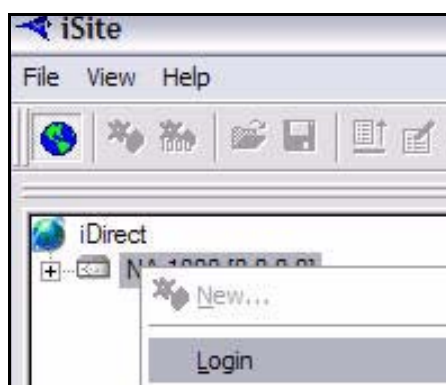

The Login dialog box opens, pre-configured with your Satellite Router's IP Address.



Figure 25. iSite Login Dialog Box

2. In the Login dialog box, type the IP Address of the Satellite Router.
3. Type the Password of the Admin account. (“iDirect” is the default password for the Admin account.)
4. In the Login As section of the dialog box:
  - a. Select Admin
  - b. Select Secure Connection.
5. Click OK.

**Note:** A new password may have been assigned at your Network Operator’s Help Desk. If you cannot log on using “iDirect”, obtain the correct password from the Network Help Desk.

**Note:** If you do not have Admin privileges, log in as User.

## 8.3 Calculate Polarization, Azimuth, and Elevation

Using iSite, calculate the polarization, azimuth, and elevation appropriate for your current location.

1. In the iSite Tree, right-click the Satellite Router and select Align Antenna→Antenna Pointing to display the Antenna Pointing dialog box (Figure 26).

**Antenna Pointing**

Look Angle Calculator | Antenna Pointing

Remote Location  
 Latitude:  Deg N. Longitude:  Deg W.

Spacecraft Position  
 Longitude:  Deg W.

Elevation Information  
 True:  deg. Horizontal = 0 deg. Straight Up = +90 deg.  
 Offset:  deg.

Gross Antenna Pointing Information  
 Elevation Actual:  deg. Actual = True - Offset  
 Azimuth True:  deg. Geographical North = 0 deg.  
 Polarization Offset:  deg. Polarization Angle Sense

Notes:  
 For observer behind antenna (facing the feed/satellite), positive is clockwise.  
 For observer behind feed (facing the dish), positive is counter-clockwise.  
 Polarization calculation is based on an operational horizontal downlink. If the operational downlink polarization is 'vertical', subtract 90 degrees from the calculated result to obtain the correct polarization value. A negative number is valid.

Close

Figure 26. iSite Antenna Pointing Dialog Box

2. On the Look Angle Calculator tab of the Antenna Pointing dialog box, the Longitude should already be configured for you in Spacecraft Position. If not, enter the appropriate Longitude for the satellite that you are using.

If you are commissioning a mobile remote, the white fields will all be blank. You must supply the following information.

3. In Remote Location, enter the Latitude and Longitude of your current geographic location. For mobile remotes, this can be determined by your GPS unit.
4. In Spacecraft Position, enter the Longitude for the satellite that you are using.
5. In Elevation Information, type the Offset for your antenna.

The offset for a 1.8 meter antenna is 22.6°.

The offset for a 1.2 meter antenna is 17°.

When you have configured all of the information, iSite automatically calculates your polarization offset, azimuth, and elevation values.

**Note:** *Write these values down, or leave this screen open on your laptop. You will need these values later to perform the initial pointing of your antenna.*

## 8.4 Perform Pulse Width Modulation (PWM) Antenna Pointing

Next, you must fine-tune the antenna pointing by locking onto the downstream carrier for your network and sweeping the antenna in azimuth until you obtain a reading of 12 to 24 volts DC. Readings in this range indicate that you have successfully locked onto the correct satellite.

Table 2. Signal Strength Ranges (PWM)

<i>Signal Strength Ranges</i>	
Volts DC	Antenna Status
0 - 2	Not in pointing mode, hardware problem, or off satellite
2 - 10	Detecting RF energy, but not locked on the downstream carrier
12 - 24	Locked on the downstream carrier

**Note:** *You can only obtain a reading of 12 volts or greater when you are locked onto the correct spacecraft or network.*

If you are not already connected to the Satellite Router, power it on, launch iSite, and connect to the Satellite Router by following the instructions beginning on [page 13](#) of this manual.

1. In the iSite Tree View, right-click the Satellite Router and select **Align Antenna**→**Antenna Pointing** to display the Antenna Pointing dialog box ([Figure 26](#) on [page 29](#)).

2. Click the Antenna Pointing tab.

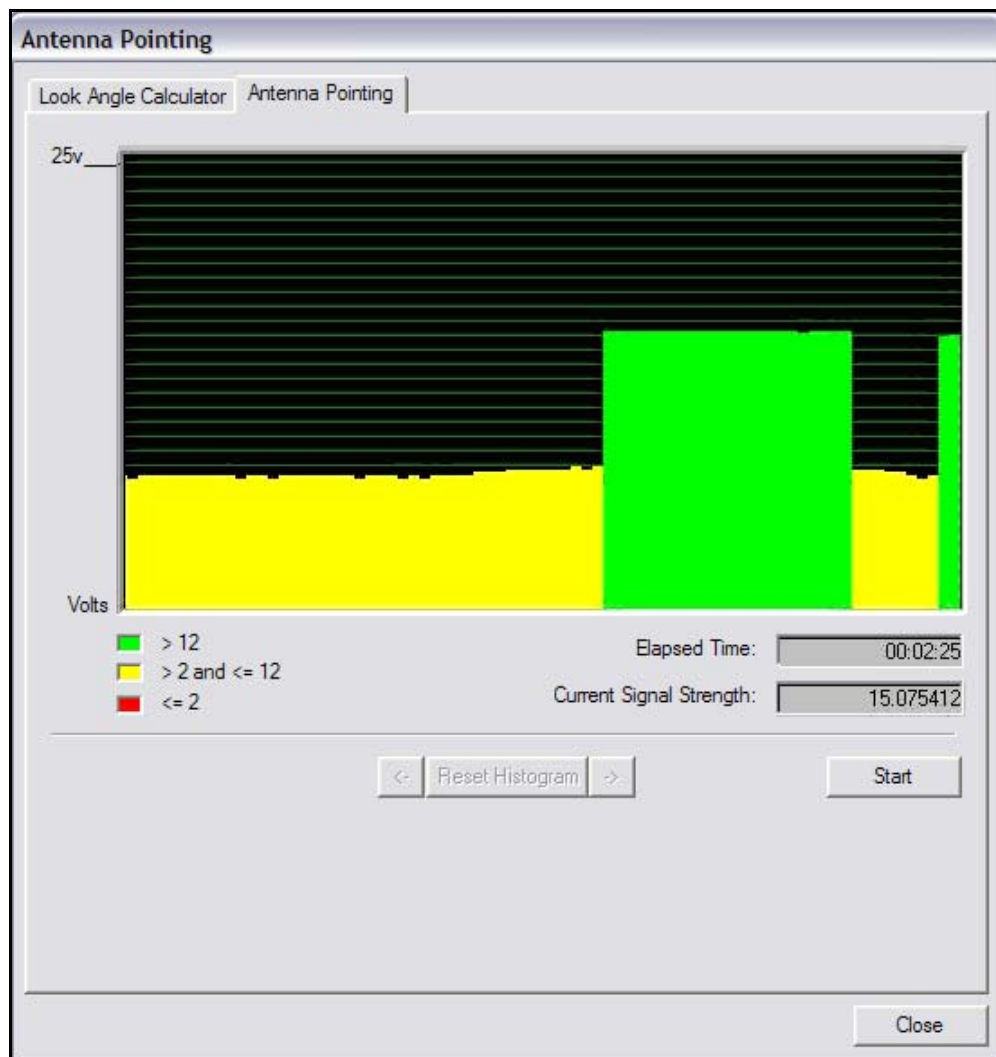

Figure 27. Comparing Signal Strength

3. Slowly sweep the reflector in azimuth until a signal of the appropriate strength is found. The signal reading on the pointing graph will turn red, then yellow, and finally, completely green, as you sweep the reflector to lock on to the downstream carrier.

When you have achieved strong signal strength on the correct satellite, you should see:

- A green reading on the Antenna Pointing graph
- A reading within the desired range for the Current Signal Strength
- A signal within the correct range on your digital voltmeter ( $\geq 12$  volts)

Figure 28 shows an example of the iSite Antenna Pointing graph when the antenna is locked onto the correct downstream carrier.

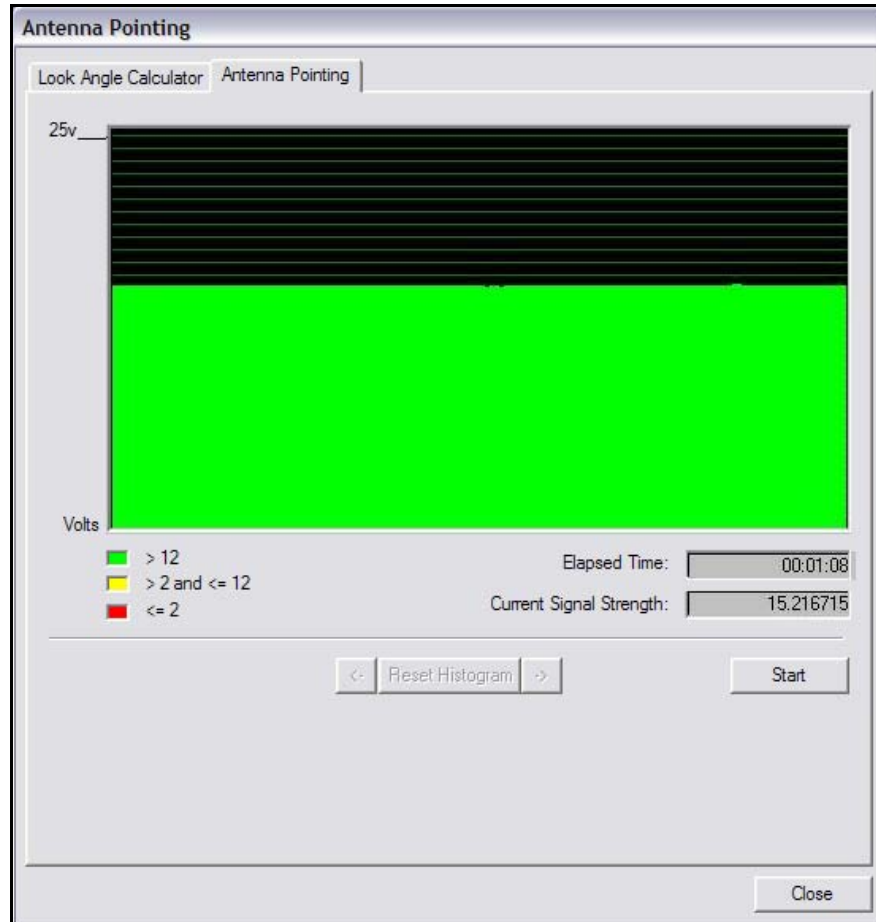

Figure 28. Locking on to a Carrier Stream

**Note:** *You will not obtain a reading in the correct range from the wrong spacecraft or network.*

4. If the desired signal is not found, increase or decrease the elevation setting by  $2^\circ$  increments and repeat the azimuth sweep until the correct signal is found. (See [Step 5](#) on [page 29](#).)
5. When you have locked onto the carrier:
  - a. Tighten the four bolts on the Yoke Cap that secure the Yoke Cap to the Mast Pipe.
  - b. Ensure that the Top Plate locking bolts are snug to allow azimuth movement.
  - c. Adjust the elevation until maximum DC voltage is obtained.

6. Make the remaining azimuth adjustments with the azimuth adjustment screws:
  - a. Fine tune azimuth until maximum DC voltage is obtained.
  - b. Make sure azimuth and elevation are locked down.
  - c. Adjust the polarization until maximum DC voltage is obtained.
7. Write down the final antenna pointing voltage reading and report the reading to the Network Operator.
8. In the Antenna Pointing dialog box, click Stop to exit the modem's antenna pointing mode.
9. Power off the Satellite Router.

**Note:** *You must power off the Satellite Router before continuing to the next section, [“Tuning Antenna Pointing and Cross Polarization” on page 35.](#)*



---

---

# 9 Tuning Antenna Pointing and Cross Polarization

Perform these steps to fine-tune the antenna pointing and cross polarization.

## 9.1 Set up the Satellite Router for Cross Polarization

1. Power off the Satellite Router to set it up for cross polarization.
2. Disconnect the receive IFL cable from the Satellite Router.
3. Disconnect the transmit IFL cable from the Digital Volt Meter and connect it to the BUC.

## 9.2 Set up iSite for Cross Polarization

The remote portion of the cross polarization test is conducted from the iSite GUI.

1. Power on the Satellite Router.
2. Launch iSite and connect to the Satellite Router using its IP address.
3. Log on as Admin with a valid password.
4. In the iSite menu bar, select **Align Antenna**→**Cross Polarization** from the **Configure** menu to open the **Cross Polarization** dialog box.

The image shows a screenshot of the 'Cross Polarization' dialog box. The dialog box is titled 'Cross Polarization' and contains the following fields and buttons:

- Specify Transmit Frequency:**
  - RF Uplink Frequency: 0 MHz
  - BUC LO Frequency: 0 MHz
  - L-Band TX Frequency (Absolute Value): 0.000 MHz
- Adjust Transmit Power:**
  - Transmit Power: 25.0 dBm
- Buttons:** Start CW, Modulate On, Stop, Close

Figure 29. Cross Polarization Dialog Box

## 9.3 Preparing for the Cross Polarization Test

1. While still logged on to iSite, call the Network Operator. The Network Operator will establish a conference call between you, the Network Operator, and the satellite provider.
2. Provide the final antenna pointing voltage reading to the Network Operator. He will record the value for their records.
3. Obtain the test frequency from the satellite provider
4. In RF Uplink Frequency of the **Cross Polarization** dialog box (Figure 29), type the test frequency.

The BUC LO frequency is read from the options file on your Satellite Router. Using these values, iSite automatically calculates the L-band TX frequency.

5. Verify the L-band TX frequency with the Network Operator.

The BUC LO frequency will typically show a value of 13050 MHz for Ku band and 4900 for C band. These values are read from the options file on your Satellite Router. Using the RF Uplink and BUC LO frequencies, iSite automatically generates an L-band frequency for the Satellite Router.

## 9.4 Running the Cross Polarization Test

1. When instructed by the satellite provider, click the Start CW button on the Cross Polarization dialog box (Figure 29). This will program the Satellite Router with the calculated L-band frequency.

**WARNING! Do not click the Start CW button until instructed to do so by the satellite provider. When you do click Start CW, your Satellite Router will start transmitting a Continuous Wave Carrier, or "CW."**

**WARNING! You may receive an error message after clicking the Start button. If this happens, click the Stop button and try again.**

2. If the Satellite Provider asks you to adjust the Satellite Router's transmit power, select the appropriate power value in the Transmit Power box.

The satellite provider will ask you to adjust the azimuth, polarization, and/or elevation. The polarization is typically adjusted first. If the correct isolation cannot be achieved, then the operator may ask you to adjust the azimuth and/or elevation.

### 9.4.1 Adjusting Azimuth

1. Adjust the azimuth and the elevation by making  $\frac{1}{4}$  turns of the adjustment nut. Then wait for the satellite provider to measure the cross polarization reading. The provider will instruct you to continue adjusting in the same direction or to reverse the direction.
2. Adjust the azimuth by loosening all four bolts on top of the canister as little and as evenly as possible.

**WARNING! Loosening the four bolts too much, or adjusting some of them more than others, will throw off the elevation more than necessary.**

3. After the azimuth has been adjusted, ensure that the four bolts and the fine adjustment rod are completely tightened, so that the elevation is not affected later.

### 9.4.2 Adjusting Elevation

The elevation adjustment is performed in the same manner as the azimuth adjustment.

1. Using the elevation rod/nut, adjust the elevation.
2. Once the elevation is adjusted, make certain that the elevation rod and nuts are completely tightened.

### 9.4.3 Adjusting the Polarization

To adjust the polarization:

1. Loosen the two screws at the feed.
2. Loosen the hose clamp on the back end of the BUC just enough that the entire assembly (feed, BUC, and LNB) will rotate freely.
3. At the instruction of the satellite provider, move the feed in one direction in approximately  $1/2^\circ$  increments, or as little as possible.
4. Wait for the satellite provider to take a measurement. The satellite provider may tell you to continue moving the feed in the same direction, or to reverse the direction. Continue until the satellite provider tells you that the polarization is peaked.
5. Tighten the two screws and the hose clamp to secure the outdoor unit.

At this point, the canister bolts on the pole should be completely tightened.

### 9.4.4 After the Cross Polarization Test

1. Wait for the Satellite Provider to verify that the cross polarization is still correct after everything is tightened.
2. Confirm that the Network Operator has recorded the cross polarization results.
3. Proceed to the 1 dB Compression Point test.



---

---

# 10 Establishing the 1 dB Compression Point

Perform the 1 dB Compression Point test with the same CW setup used during the cross polarization test. This test determines the point at which the Satellite Router's transmit power saturates the BUC.

**WARNING! To avoid overdriving the satellite, do not conduct this test if the power of the BUC exceeds five watts.**

1. With the iSite Cross Polarization dialog box still opened, and with the Network Operator watching the CW, increase the transmit power of the carrier in the Adjust Transmit Power drop-down box by 1 dBm increments.

**WARNING! The operator should see the CW increase in power by approximately 1 dB. If the power does not increase, then the BUC may already be saturated. Although this scenario is unusual, it can occur.**

2. If power does not increase, decrease the power by 1 dBm until the operator sees the CW decrease by 1 dB.

**Note:** *The last point at which the CW changes by 1 dB is the 1 dB compression point.*

3. Record the TX power value. This will be entered into iBuilder as the maximum power for this remote used by the NMS.
4. Click the Stop on the button Cross Polarization dialog box to turn off the CW carrier. Then exit iSite.

The 1 dB compression point has now been established.

This completes the Satellite Provider's portion of the call. Disconnect the Satellite Provider from the call.

Do not power off the Satellite Router yet.



---

---

# 11 Recording Geo Location (Secure Mobile Remotes Only)

Follow the procedure in this section to set the geographical location of the Satellite Router for secure mobile remotes.

**Note:** *This section describes a specific operational scenario for configuring Satellite Routers as both Mobile and Secure. If your remotes do not fall into this category, skip this section.*

If for security reasons the Satellite Router's geographic location coordinates have not been recorded by the Network Operator, you must enter these coordinates into the Satellite Router manually, before the modem will acquire into the network.

**WARNING!** *It is critical that the geographic coordinates accurately reflect your current geographic location. If the values are incorrect, your Satellite Router will not be acquired into the network.*

## 11.1 Set the Satellite Router's Geo Location

Enter the latitude and longitude coordinates from the Satellite Router console using the `latlong` command.

1. Open a terminal session to the Satellite Router. (You can use HyperTerminal or TeraTerminal to create a serial connection to the console port. You can also use TeraTerminal or PuTTY to telnet to the Satellite Router over the LAN.)
2. Log in as root and `telenet localhost` to the Admin account. See [“Access Your Satellite Router Using HyperTerminal” on page 5](#) for details, including default passwords.
3. At the prompt, enter the following command:

```
latlong <your lat> [N|S] <your long> [E|W]
```

### Format of the latlong Command

The format of the `latlong` command is: `latlong <lat> [N/S] <long> [E/W]`  
When entering this command, replace the `<lat>` string with your current latitude in decimal notation, followed by N for north or S for south. Replace the `<long>` string with your current longitude in decimal notation, followed by E for east or W for west.

---

## 11.2 Verify the Satellite Router's Geo Location

Verify that you have entered the correct geographic location coordinates.

1. Enter `extras show` at the console prompt to display the current settings for latitude and longitude.
2. Reset the Satellite Router.

---

---

# 12 Bringing the Satellite Router into the Network

After you have entered the correct geographic coordinates for your current location and reset the Satellite Router, the Satellite Router should perform its power-up self-test and acquire into the network. Observe the LEDs on the front of the Satellite Router while the network powers on and goes through the acquisition process. You will see various combinations of front-panel lights indicating the current status of the Satellite Router.

The first time that the Satellite Router joins the network, complete the post-acquisition activities described in this document. If your Satellite Router does not acquire into the network, contact the Network Operator for assistance. [Table 3](#) and [Table 4](#) specify the status of the Evolution e8350 and iNFINITI Satellite Routers as indicated by the front panel LEDs.

## 12.1 Evolution e8350 Satellite Router Front Panel LEDs

Various combinations of the LEDs on the front panel of the Evolution e8350 Satellite Router indicate the different states of your iDirect Satellite Router.

Table 3. iDirect Evolution e8350 LED Status

LED Label	LED Color	Indicated Unit Status
PWR	Off	The Satellite Router is powered Off or there is a power supply problem.
	Green	The Satellite Router is powered On.
NET	Green	The Satellite Router has been acquired into the network.
	Flashing Green	The Satellite Router is attempting acquisition into the network.
	Solid Yellow	The downstream carrier is locked.
	Flashing Yellow	The downstream carrier is not locked.
STATUS	Green	The IDU is functioning properly.
	Flashing Green	The unit is booting. The DRAM test is in progress.
	Red	Indicates a serious fault or failure in the software, hardware or configuration. May indicate that the DRAM test failed.
TX	Green	The IDU's transmitter is active.
	Yellow	The transmitter is disabled.

Table 3. iDirect Evolution e8350 LED Status (*continued*)

LED Label	LED Color	Indicated Unit Status
RX	Green	The IDU is locked to the downstream and receiving data.
	Yellow	The IDU is not locked to the downstream carrier.
CRYPTO	Green	FIPS mode is enabled.
	Off	FIPS mode is not enabled.
FAN	Off	No fan alarm detected.
	Red	Fan alarm detected.
TEMP	Yellow	Operating temperature is approaching the over-temperature threshold.
	Red	Operating temperature threshold has been exceeded.

## 12.2 iNFINITI Satellite Router Front Panel LEDs

Various combinations of the LEDs on the front panel of the iNFINITI Satellite Router indicate the different states of your remote modem.

Table 4. iDirect iNFINITI LED Status

LED Label	LED Color	Indicated Unit Status
PWR	Off	The Satellite Router is powered Off or there is a power supply problem.
	Green	The Satellite Router is powered On.
NET	Green	The Satellite Router has been acquired into the network.
	Flashing Green	The Satellite Router is attempting acquisition into the network.
	Solid Yellow	The downstream carrier is locked.
	Flashing Yellow	The downstream carrier is not locked.
STATUS	Green	The IDU is functioning properly in TRANSEC mode.
	Off	The IDU is functioning properly in non-TRANSEC mode.
	Flashing Green	The unit is booting. The DRAM test is in progress.
	Red	Indicates a serious fault or failure in the software, hardware or configuration. May indicate that the DRAM test failed.
TX	Green	The IDU's transmitter is active.
RX	Green	The IDU is successfully locked to the downstream.
	Yellow	The IDU is not locked to the downstream carrier.

## 12.3 Evolution X3 and X5 Satellite Router Front Panel LEDs

Various combinations of the LEDs on the front panel of the Evolution X3 Satellite Router indicate the different states of your remote modem.

Table 5. iDirect Evolution X3 and X5 LED Status

LED Label	LED Color	Indicated Unit Status
PWR	Off	The Satellite Router is powered Off or there is a power supply problem.
	Green	The Satellite Router is powered On.
NET	Green	The Satellite Router has been acquired into the network.
	Flashing Green	The Satellite Router is attempting acquisition into the network.
	Solid Yellow	The downstream carrier is locked.
	Flashing Yellow	The downstream carrier is not locked.
STATUS	Off	The IDU is functioning properly.
	Flashing Green	The unit is booting. The DRAM test is in progress.
	Red	Indicates a serious fault or failure in the software, hardware or configuration. May indicate that the DRAM test failed.
TX	Green	The IDU's transmitter is active.
RX	Green	The IDU is locked to the downstream and receiving data.
	Flashing Green	The demodulator is locked to the downstream but NCR is not locked. Data is not being received by the modem.
	Yellow	The IDU is not locked to the downstream carrier.



---

---

# 13 Post Acquisition Activities

To guarantee trouble-free operation of your Satellite Router, certain activities should be completed after the Satellite Router comes into the network for the first time. Some of these activities are performed by the Network Operator. Other activities are performed by you.

## 13.1 Network Operator Duties

After commissioning the Satellite Router for the first time and after it has acquired into the network, the Network Operator will take control of the Satellite Router to perform the following tasks.

**WARNING! Do not power down the Satellite Router during this time.**

1. The Network Operator will follow the procedure in [“Setting Initial Power and Maximum Power” on page 49](#) to set the initial transmit power, maximum transmit power, and UCP settings for the remote. For star remotes, initial transmit power is typically set to 2 to 3 dB above nominal transmit power in clear sky conditions. Maximum transmit power is set for the 1 dB compression point.

**WARNING! Setting the initial power too high above the normal operating levels can cause problems with the remote acquiring into the network or cause problems on the network.**

2. If this is an uncertified Remote in a TRANSEC network, the Network Operator will issue an X.509 certificate to the remote and enable authentication on the Remote Information tab in iBuilder.
3. The Network Operator will download the updated configuration to the Satellite Router and issue a reset.
4. The Network Operator will record levels of the Satellite Router as a baseline for troubleshooting.
5. The Network Operator will ensure that the software and firmware on the Satellite Router are at the correct revision level. If necessary they will upgrade the software on the Satellite Router and issue a reset.

The Network Operator will let you know when all tasks are complete.

## 13.2 Remote Installer Duties

After the Network Operator has made any necessary adjustments to the Satellite Router's configuration, you should record some baseline readings for local reference, in case the antenna is moved, or some other service issue arises. Follow this procedure to record the baseline readings.

1. Open a terminal session to the Satellite Router. (You can use HyperTerminal or TeraTerminal to create a serial connection to the console port. You can also use TeraTerminal or PuTTY to connect to the Satellite Router over the LAN.)
2. Log in as root and `telnet localhost` to the Admin account. See [“Access Your Satellite Router Using HyperTerminal” on page 5](#) for details, including default passwords.
3. At the prompt, enter the `rmtstat` command to view the remote status message.

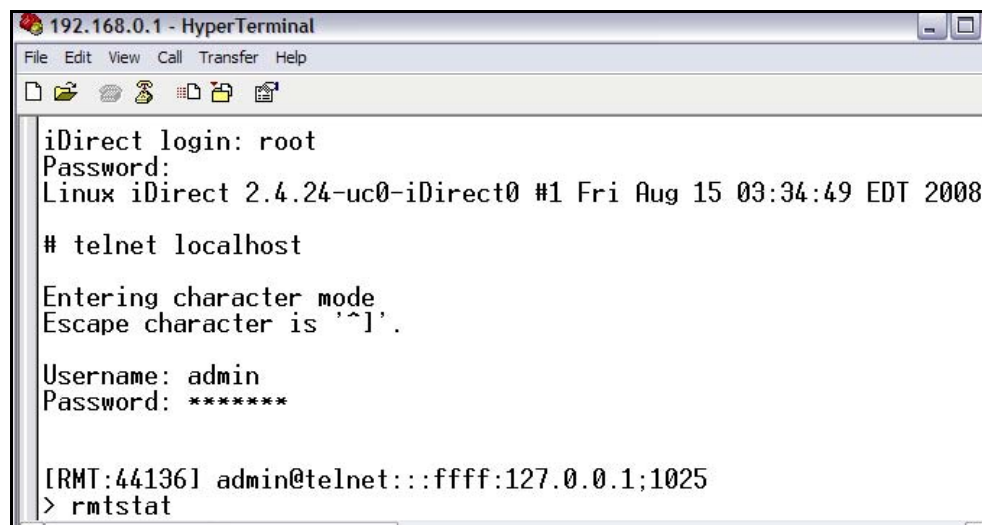

```

192.168.0.1 - HyperTerminal
File Edit View Call Transfer Help
iDirect login: root
Password:
Linux iDirect 2.4.24-uc0-iDirect0 #1 Fri Aug 15 03:34:49 EDT 2008
# telnet localhost
Entering character mode
Escape character is '^]'.
Username: admin
Password: *****
[ RMT:44136 ] admin@telnet::ffff:127.0.0.1;1025
> rmtstat

```

Figure 30. Entering the `rmtstat` Command

4. Record the following data from the remote status message:
  - a. Receive SNR of the Satellite Router (> 10.0 dB, Clear Sky Conditions)
  - b. Transmit power of the Satellite Router
  - c. Receive composite power into the Satellite Router. (-60 to -5 dBm)
  - d. Temperature reading in Celsius

### Example: Remote Status Message

```
RemoteStatus: t:000017435715 SNR=15.60 RxPower=-33.79 dBmTxPower=-15.00 dBm
DigitalRxPower=21.07 Temp=49.1 TDM_Lost=0Flldac = 1812 LAN Port: 10 Mbps Half Duplex
(AutoNegotiation: None)
```

These readings should be checked periodically to ensure that the service is not degrading. These readings will be monitored by the Network Operator. Heavy weather or sandstorms can cause these levels to change. During heavy weather or sandstorms the levels should be monitored because it is important that they return to the original readings once the weather or sandstorm has cleared.

---

---

# 14 Setting Initial Power and Maximum Power

Once you have completed the 1 dB compression test, the hub operator must set the following parameters for the remote in iBuilder:

- Initial transmit power
- Maximum transmit power

Contact the Network Help Desk and ask the hub operator to follow the instructions in this section to set these parameters. Provide the hub operator with the results of the 1 dB compression test. The hub operator will enter this value as the maximum transmit power for the remote.

## 14.1 Determine the Remote's Initial Transmit Power

Follow this procedure to determine the initial transmit power setting for your remote.

**Note:** *You must determine the initial transmit power setting under clear sky conditions.*

1. Log on to iMonitor.
2. In iMonitor, right-click the remote in the network tree and select Probe from the menu to display the Probe dialog box.

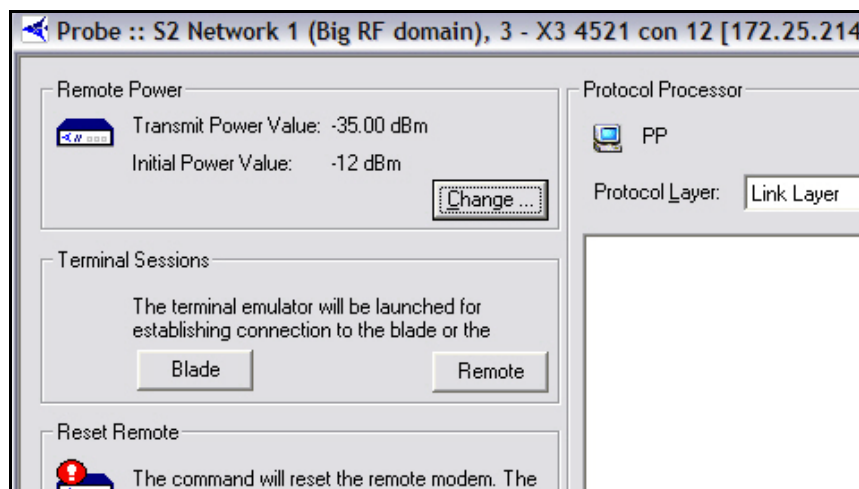

Figure 31. iMonitor Probe Dialog Box

3. In the Remote Power area of the screen, click the Change button to display the Change Remote Tx Power dialog box.

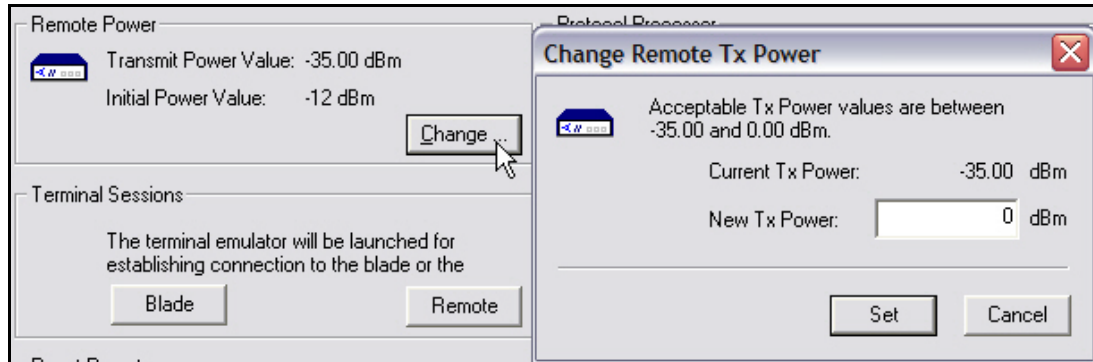

Figure 32. iMonitor Change Remote Tx Power Dialog Box

4. In the Change Remote Tx Power dialog box:
  - a. Type -25 in New Tx Power
  - b. Click Set.
  - c. If you are commissioning a TDMA remote, repeat [Step a](#) and [Step b](#) to increase the transmit power by increments of 3 dB until the remote acquires the network.
  - d. If you are commissioning an SCPC remote, repeat [Step a](#) and [Step b](#) to increase the transmit power by increments of 3 dB until the receive line card achieves TDM lock on the remote's SCPC upstream carrier.
5. In iMonitor, right-click the remote in the network tree and select Remote Status/UCP from the menu to open the RemStats (Remote Status) display for the remote.

Time	Serial #	M...	Rx Composite Power	Down C/N [dB]	Tx Pwr [dBm]	Clock DAC	Rx COF
4/25/2011 4:31:50 PM	X3.4521	X3	-35.90	22.10	-35.00	32335	1
4/25/2011 4:32:10 PM	X3.4521	X3	-35.90	22.20	-35.00	32383	1
4/25/2011 4:32:30 PM	X3.4521	X3	-35.90	22.10	-35.00	32387	1
4/25/2011 4:32:50 PM	X3.4521	X3	-35.90	22.10	-35.00	32367	1
4/25/2011 4:33:10 PM	X3.4521	X3	-35.90	22.20	-35.00	32383	1
4/25/2011 4:33:30 PM	X3.4521	X3	-35.90	22.20	-35.00	32361	1
4/25/2011 4:33:50 PM	X3.4521	X3	-35.90	22.20	-35.00	32351	1
4/25/2011 4:34:10 PM	X3.4521	X3	-35.90	22.10	-35.00	32351	1

Figure 33. iMonitor Remote Status Display

6. Select the Remote Status tab.
7. Observe the column Tx Pwr [dBm] ([Figure 33](#)).
8. Wait for the Tx Power to settle on a constant value and note the value. In the next procedure, you will set the remote's Initial Power to 2 dB to 3 dB above the Tx Power observed in iMonitor.

## 14.2 Set the Initial Power and Maximum Power for a TDMA Remote

If you are commissioning a remote to transmit on a TDMA upstream carrier, follow this procedure to set the maximum transmit power and the initial transmit power for the remote. If you are commissioning a remote to transmit an SCPC return channel, follow the procedure in [“Set the Initial Power and Maximum Power for an SCPC Remote” on page 52](#).

1. If you are commissioning a remote in a TRANSEC network, Disable Authentication for the remote on the iBuilder Remote Information tab and apply the hub-side configuration. (For more details, see the *iBuilder User Guide*, Appendix B, “Using the iDirect CA Foundry.”)
2. In iBuilder, right-click the remote in the network tree and select Modify→Item from the menu.
3. On the Information tab of the Remote dialog box, scroll down to the Transmit Properties area of the Information tab ([Figure 34](#)).

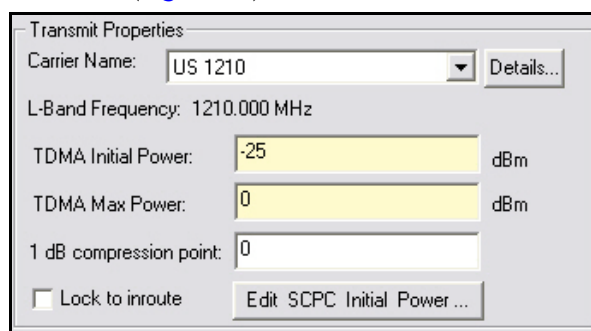

Figure 34. iBuilder Remote Information Tab: Setting TDMA Initial and Max Power

4. Set TDMA Initial Power ([Figure 34](#)) to 2 dB to 3 dB above the transmit power observed in iMonitor. (See [“Determine the Remote’s Initial Transmit Power” on page 49](#).)
5. Enter the 1 dB compression point as the value for TDMA Max Power.
6. Click **OK** on the Remote Information tab to save the changes.
7. Right-click the remote in the iBuilder network tree and select Apply Configuration→Reliable Both (TCP).
8. If you are commissioning a remote in a TRANSEC network and you have disabled authentication:
  - a. If the remote has not yet been issued an X.509 certificate, issue the certificate at this time. (See the *iBuilder User Guide*, Appendix B, “Using the iDirect CA Foundry” for details.)
  - b. Re-enable authentication on the remote Information tab by clearing the Disable Authentication check box.
  - c. Click **OK** to save the changes.
  - d. Right-click the remote in the network tree and apply the configuration by selecting Apply Configuration→Reliable Both (TCP).

## 14.3 Set the Initial Power and Maximum Power for an SCPC Remote

If you are commissioning a remote to transmit an SCPC return channel to the hub, follow this procedure to set the maximum transmit power and the initial transmit power for the remote. If you are commissioning a remote to transmit on a TDMA upstream carrier, follow the procedure in [“Set the Initial Power and Maximum Power for a TDMA Remote” on page 51.](#)

1. In iBuilder, right-click the remote in the network tree and select **Modify**→**Item** from the menu.
2. On the **Information** tab of the Remote dialog box, scroll down to the **Transmit Properties** area of the **Information** tab (Figure 35).

Figure 35. iBuilder Remote Information Tab: Transmit Properties

3. Click the **Edit SCPC Initial Power** button to open the **SCPC Initial Power** dialog box (Figure 36).

Carrier Id	Carrier Name	Initial Power	Max Power
25	US 1630 SCPC		
26	US 1640 SCPC		
28	US 1632 SCPC		
35	US 1634 SCPC		
36	US 1850 SCPC SS		
38	US 1848 SCPC SS		
46	US 1500 SCPC		
47	US 1510 SCPC		
48	US 1520 SCPC	-33.0	2.0
49	US 1502 SCPC		

Figure 36. SCPC Initial Power Dialog Box: Setting SCPC Initial and Max Power

4. In the **SCPC Initial Power** dialog box, double-click the cell in the **Initial Power** column of the SCPC return carrier for which you are commissioning this remote and enter a value that is 2 dB to 3 dB above the transmit power observed in iMonitor. (See [“Determine the Remote’s Initial Transmit Power” on page 49.](#))

5. Double-click the cell in the Max Power column of the SCPC return carrier for which you are commissioning this remote. Then enter the value determined for the 1 dB compression point.
6. Click OK in the SCPC Initial Power dialog box to return to the Remote Information tab.
7. Click **OK** on the Remote Information tab to save the changes.
8. Right-click the remote in the network tree and apply the configuration by selecting Apply Configuration→Reliable Both (TCP).

**Note:** *In iBuilder, you can configure the Max Power and Initial Power for multiple SCPC upstream carriers per remote to facilitate switching the remote from one SCPC return channel to another. If this remote will be transmitting more than one SCPC return channel, repeat these procedures to determine and set the correct Initial Power for each carrier. The Initial Power may vary per carrier depending on a number of factors, including the carrier's transponder, symbol rate, modulation, FEC rate, block size, etc.*



---

---

# Appendix A Loading Images using the TFTP Server

An alternate method of downloading the images to your Satellite Router is to use the TFTP server that comes bundled with iSite.

1. Open iSite and select TFTP from the File menu.
2. A pop up window will prompt you to select the TFTP server local folder. Browse and select the folder in which the remote package resides.
3. Open a console session to the remote unit and log on to the Linux prompt as root.
4. Enter `service idirect_falcon stop`. This will stop the iDirect application.
5. Enter `tftp_package.sh <IP address of TFTP server> <package name>`.  
For example, if your laptop's IP address is 10.10.1.2 and you are loading 9.0.0.4 remote package the command will be `tftp_package.sh 10.10.1.2 remote 9_0_0_4.pkg`.
6. Once the transfer is complete, reset the remote using the `reboot` command.



---

---

# Appendix B Pointing the Antenna Using the Console Port

This section describes the procedure for pointing the antenna using the console port and a digital voltmeter (DVM). This is an alternate method to that presented in [“Pointing the Antenna Using iSite” on page 27](#).

## B.1 Performing Console Antenna Pointing

When using console pointing, the Rx and Tx cables from the Satellite Router can remain connected to the LNB and BUC, respectively.

Pin 8 on the RJ-45 connector *must* be pinned to pin 8 on the DB-9 connector to read DVM voltages from the serial port.

**WARNING!** *The following section must be completed to ensure that damage is not done to the BUC and that console pointing works correctly.*

## B.2 Disable the Transmit PWM Voltage

The remote options file *must* contain the following line in the [ODU] group:

```
odu_disable_tx_pwm = 1
```

Setting this value to 1 disables the transmit PWM voltage normally present on the transmit IFL cable.

**WARNING!** *When odu\_disable\_tx\_pwm is set to zero, DC voltage will be present on the transmit IFL cable at the BUC (Block Up-Converter) during the pointing process. This could cause damage to the BUC and potentially generate an unwanted carrier.*

**Note:** *This procedure assumes you have a remote-side options file available with odu\_disable\_tx\_pwm set to 1.*

Follow these steps to download the options file with PWM disabled to the remote:

1. Power on the Satellite Router and let it boot up completely.
2. Follow the procedure on [page 13](#) to log on to the remote using iSite.
3. Follow the procedure in [“Downloading the Options File to the Satellite Router” on page 21](#) to download the options file with Tx PWM disabled and reset the Satellite Router.

4. After the Satellite Router resets, log on again using iSite.
5. In iSite, right-click the Satellite Router and select Upload Option to Disk to retrieve the remote options file.
6. Verify that the line `odu_disable_tx_pwm = 1` is present in the options file. Do not start console pointing if this line is not present in the options file or you will damage your hardware.

## B.3 Starting Console Pointing

To start console pointing:

1. If you do not have a console connection to the Satellite Router, follow the procedure in [“Connecting to the Satellite Router” on page 5](#) to establish one now.
2. After logging on to the admin account, enter the following console commands:

```
rx pointing enable
```

```
rx pointing on
```

At this point, the Satellite Router is in console pointing mode.

## B.4 Using the DVM for Console Pointing

To use the digital voltmeter for console pointing, complete the following steps.

1. Disconnect the console port from the laptop, leaving the RJ-45 connector connected to the Satellite Router.
2. From the DB-9 connector, connect pin 4 or 5 (GND) to the negative probe on the DVM.
3. Connect pin 8 (+) to the positive probe on the DVM.
4. Point the antenna using the normal procedure, until the signal falls into the desired range ([Table 6](#)).

Table 6. Signal Strength Ranges (DVM)

Signal Strength Ranges	
Volts DC	Antenna Status
0-2.5 VDC	RF energy is detected, but from the wrong satellite
2.6 - 5.0 VDC	Carrier lock, correct satellite

**Note:** *The LEDs the front panel of the Satellite Router will verify Carrier Lock. See [Table 3 on page 43](#), [Table 4 on page 44](#) and [Table 5 on page 45](#) for details on remote LED status indicators.*

5. Re-enable transmit pwm voltage by reloading the options file with `odu_disable_tx_pwm = 0`.

---

---

# Appendix C Disabling the PWM Voltage in iBuilder

If you have access to iBuilder, you can verify that the transmit PWM voltage normally present on the transmit IFL cable is disabled.

To verify the transmit PWM voltage normally present on the transmit IFL cable is disabled through iBuilder perform the following steps.

1. Power up the Satellite Router and let it boot up completely.
2. In iBuilder, right-click the remote and select Modify→Item.

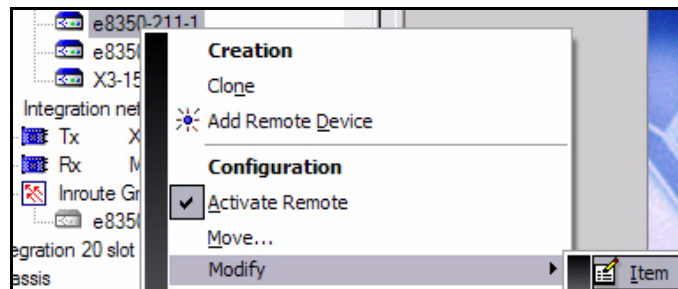

The Remote Information tab opens.

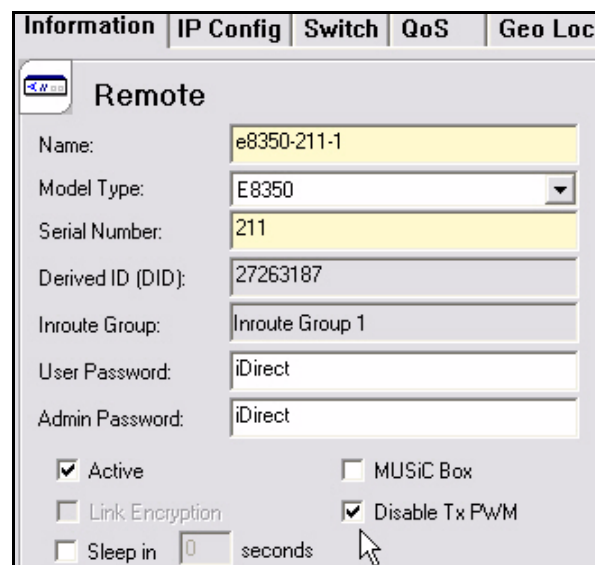

Figure 37. iBuilder Remote Information Tab: Disabling Tx PWM

3. On the Remote Information tab, select Disable Tx PWM if it is not already selected.
4. Apply the new configuration and reset the Satellite Router.

---

---

# Appendix D Pinout for RJ-45 to DB-9 Adapter

In addition to the Satellite Router console cable, you will need an RJ-45 to DB-9 adapter. The pinouts are as follows:

Table 7. DB-9 to RJ-45 Adapter Pinout

DB-9 to RJ-45 Adapter Pin-Out		
RJ-45	Color Code	DB-9
1	Blue	8
2	Orange	6
3	Black	2
4	Red	5
5	Green	N.C.
6	Yellow	3
7	Brown	4
8	White/Gray	7

**iDirect, Inc.**

13865 Sunrise Valley Drive

Herndon, VA 20171

+1 703.648.8000

+1 866.345.0983

[www.idirect.net](http://www.idirect.net)

*Advancing a Connected World*